

CONSOLIDATED VERSION



**Environmental testing –
Part 2-58: Tests – Test Td: Test methods for solderability, resistance to
dissolution of metallization and to soldering heat of surface mounting devices
(SMD)**



THIS PUBLICATION IS COPYRIGHT PROTECTED
Copyright © 2017 IEC, Geneva, Switzerland

All rights reserved. Unless otherwise specified, no part of this publication may be reproduced or utilized in any form or by any means, electronic or mechanical, including photocopying and microfilm, without permission in writing from either IEC or IEC's member National Committee in the country of the requester. If you have any questions about IEC copyright or have an enquiry about obtaining additional rights to this publication, please contact the address below or your local IEC member National Committee for further information.

IEC Central Office
3, rue de Varembe
CH-1211 Geneva 20
Switzerland

Tel.: +41 22 919 02 11
Fax: +41 22 919 03 00
info@iec.ch
www.iec.ch

About the IEC

The International Electrotechnical Commission (IEC) is the leading global organization that prepares and publishes International Standards for all electrical, electronic and related technologies.

About IEC publications

The technical content of IEC publications is kept under constant review by the IEC. Please make sure that you have the latest edition, a corrigenda or an amendment might have been published.

IEC Catalogue - webstore.iec.ch/catalogue

The stand-alone application for consulting the entire bibliographical information on IEC International Standards, Technical Specifications, Technical Reports and other documents. Available for PC, Mac OS, Android Tablets and iPad.

IEC publications search - www.iec.ch/searchpub

The advanced search enables to find IEC publications by a variety of criteria (reference number, text, technical committee,...). It also gives information on projects, replaced and withdrawn publications.

IEC Just Published - webstore.iec.ch/justpublished

Stay up to date on all new IEC publications. Just Published details all new publications released. Available online and also once a month by email.

Electropedia - www.electropedia.org

The world's leading online dictionary of electronic and electrical terms containing 20 000 terms and definitions in English and French, with equivalent terms in 16 additional languages. Also known as the International Electrotechnical Vocabulary (IEV) online.

IEC Glossary - std.iec.ch/glossary

65 000 electrotechnical terminology entries in English and French extracted from the Terms and Definitions clause of IEC publications issued since 2002. Some entries have been collected from earlier publications of IEC TC 37, 77, 86 and CISPR.

IEC Customer Service Centre - webstore.iec.ch/csc

If you wish to give us your feedback on this publication or need further assistance, please contact the Customer Service Centre: csc@iec.ch.

CONSOLIDATED VERSION



**Environmental testing –
Part 2-58: Tests – Test Td: Test methods for solderability, resistance to
dissolution of metallization and to soldering heat of surface mounting devices
(SMD)**

INTERNATIONAL
ELECTROTECHNICAL
COMMISSION

ICS 19.040; 31.190

ISBN 978-2-8322-4676-4

Warning! Make sure that you obtained this publication from an authorized distributor.

REDLINE VERSION



**Environmental testing –
Part 2-58: Tests – Test Td: Test methods for solderability, resistance to
dissolution of metallization and to soldering heat of surface mounting devices
(SMD)**

CONTENTS

FOREWORD.....	5
1 Scope.....	7
2 Normative references	7
3 Terms and definitions	8
4 Grouping of soldering processes and related test severities	9
5 Test equipment.....	10
5.1 Solder bath	10
5.2 Reflow equipment	10
6 Test Td ₁ : Solderability of terminations.....	11
6.1 Object and general description of the test	11
6.2 Specimen preparation	11
6.3 Accelerated ageing	11
6.4 Initial measurements.....	11
6.5 Method 1: Solder bath.....	11
6.5.1 Solder bath.....	11
6.5.2 Solder and flux	11
6.5.3 Test procedure and conditions.....	12
6.6 Method 2: Reflow.....	14
6.6.1 Reflow equipment.....	14
6.6.2 Solder paste	14
6.6.3 Test substrates.....	14
6.6.4 Test procedure	14
6.6.5 Reflow temperature profile for Test Td ₁	15
6.6.6 Test conditions	16
7 Test Td ₂ : Resistance to soldering heat.....	16
7.1 Object and general description of the test	16
7.2 Specimen preparation	16
7.3 Preconditioning.....	16
7.4 Initial measurements.....	16
7.5 Method 1: Solder bath.....	17
7.5.1 Solder bath.....	17
7.5.2 Solder and flux	17
7.5.3 Test procedure and conditions.....	17
7.6 Method 2: Reflow.....	19
7.6.1 Reflow equipment.....	19
7.6.2 Solder paste	19
7.6.3 Test substrates.....	19
7.6.4 Test procedure and conditions.....	19
8 Test Td ₃ : Dewetting and resistance to dissolution of metallization.....	21
8.1 Object and general description of the test	21
8.2 Specimen preparation	21
8.3 Initial measurements.....	22
8.4 Method 1: Solder bath.....	22
8.4.1 Solder bath.....	22
8.4.2 Solder and flux	22

8.4.3	Test procedure and conditions	22
8.5	Method 2: Reflow	22
8.5.1	Reflow equipment	22
8.5.2	Specimen	22
8.5.3	Solder paste	22
8.5.4	Flux	22
8.5.5	Reflow profile	22
8.5.6	Placement of the specimen	23
8.5.7	Application of the reflow profile	23
8.5.8	Evaluation	23
9	Final measurements	23
9.1	Flux removal	23
9.2	Recovery conditions	23
9.3	Evaluation	23
9.3.1	Wetting	23
9.3.2	Dewetting	24
9.3.3	Resistance to soldering heat	25
9.3.4	Resistance to dissolution of metallization	25
10	Information to be given in the relevant specification	25
10.1	General	25
10.2	Solderability	25
10.3	Resistance to soldering heat, dewetting and resistance to dissolution of metallization	26
Annex A (normative) Criteria for visual examination		27
A.1	Evaluation of wetting	27
A.1.1	General	27
A.1.2	Evaluation of Criteria for wetting	27
A.1.3	Evaluation of method 2 (Td₁) Additional criteria for wetting, method 2	28
A.2	Evaluation of dewetting, method 2	29
Annex B (informative) Guidance		31
B.1	General	31
B.2	Limitations	31
B.3	Choice of severity	31
B.3.1	Test Td ₁ : Solderability by solder bath method	31
B.3.2	Test Td ₂ : Resistance to soldering heat – Solder bath method	32
B.3.3	Test Td ₂ : Resistance to soldering heat –Reflow method	32
B.3.4	Immersion attitude	33
B.3.5	Test Td ₃ : Dewetting and resistance to dissolution of metallization for 30 s at 260 °C	33
Annex C (normative) Application of the test methods to through hole reflow soldering components (THR)		34
C.1	Solderability	34
C.2	Resistance to soldering heat	34
C.3	Dewetting	34
C.4	Criteria for evaluation	34
Annex X (informative) Cross reference for references to the prior revision of this specification		35
Bibliography		37

Figure 1 – Examples of immersion attitudes.....	13
Figure 2 – Reflow temperature profile for solderability	15
Figure 3 – Examples of immersion attitude.....	18
Figure 4 – Reflow temperature profile for resistance to soldering heat	20
Figure 5 – Example for placement of a specimen to a test substrate	23
Figure 6 – Identification of areas on metallic termination.....	24
Figure A.1 – Evaluation of wetting.....	28
Figure A.2 – Evaluation of dewetting.....	30
Table 1 – Grouping of soldering processes and typical test severities – Overview.....	10
Table 2 – Solder alloy and flux for test Td ₁	12
Table 3 – Solderability – Test conditions and severity, solder bath method	14
Table 4 – Solder paste specification	14
Table 5 – Solderability – Test conditions – Method 2: Reflow	16
Table 6 – Resistance to soldering heat – Test conditions and severity, solder bath method	19
Table 7 – Resistance to soldering heat – Test conditions and severity, reflow method	21
Table 8 – Dewetting and resistance to dissolution of metallization – Test conditions and severity, solder bath method	22
Table B.1 – Test conditions.....	32
Table C.1 – Test conditions for solderability test	34

INTERNATIONAL ELECTROTECHNICAL COMMISSION

ENVIRONMENTAL TESTING –

Part 2-58: Tests – Test Td: Test methods for solderability, resistance to dissolution of metallization and to soldering heat of surface mounting devices (SMD)

FOREWORD

- 1) The International Electrotechnical Commission (IEC) is a worldwide organization for standardization comprising all national electrotechnical committees (IEC National Committees). The object of IEC is to promote international co-operation on all questions concerning standardization in the electrical and electronic fields. To this end and in addition to other activities, IEC publishes International Standards, Technical Specifications, Technical Reports, Publicly Available Specifications (PAS) and Guides (hereafter referred to as “IEC Publication(s)”). Their preparation is entrusted to technical committees; any IEC National Committee interested in the subject dealt with may participate in this preparatory work. International, governmental and non-governmental organizations liaising with the IEC also participate in this preparation. IEC collaborates closely with the International Organization for Standardization (ISO) in accordance with conditions determined by agreement between the two organizations.
- 2) The formal decisions or agreements of IEC on technical matters express, as nearly as possible, an international consensus of opinion on the relevant subjects since each technical committee has representation from all interested IEC National Committees.
- 3) IEC Publications have the form of recommendations for international use and are accepted by IEC National Committees in that sense. While all reasonable efforts are made to ensure that the technical content of IEC Publications is accurate, IEC cannot be held responsible for the way in which they are used or for any misinterpretation by any end user.
- 4) In order to promote international uniformity, IEC National Committees undertake to apply IEC Publications transparently to the maximum extent possible in their national and regional publications. Any divergence between any IEC Publication and the corresponding national or regional publication shall be clearly indicated in the latter.
- 5) IEC itself does not provide any attestation of conformity. Independent certification bodies provide conformity assessment services and, in some areas, access to IEC marks of conformity. IEC is not responsible for any services carried out by independent certification bodies.
- 6) All users should ensure that they have the latest edition of this publication.
- 7) No liability shall attach to IEC or its directors, employees, servants or agents including individual experts and members of its technical committees and IEC National Committees for any personal injury, property damage or other damage of any nature whatsoever, whether direct or indirect, or for costs (including legal fees) and expenses arising out of the publication, use of, or reliance upon, this IEC Publication or any other IEC Publications.
- 8) Attention is drawn to the Normative references cited in this publication. Use of the referenced publications is indispensable for the correct application of this publication.
- 9) Attention is drawn to the possibility that some of the elements of this IEC Publication may be the subject of patent rights. IEC shall not be held responsible for identifying any or all such patent rights.

DISCLAIMER

This Consolidated version is not an official IEC Standard and has been prepared for user convenience. Only the current versions of the standard and its amendment(s) are to be considered the official documents.

This Consolidated version of IEC 60068-2-58 bears the edition number 4.1. It consists of the fourth edition (2015-03) [documents 91/1222/FDIS and 91/1250/RVD] and its amendment 1 (2017-07) [documents 91/1445/FDIS and 91/1451/RVD]. The technical content is identical to the base edition and its amendment.

In this Redline version, a vertical line in the margin shows where the technical content is modified by amendment 1. Additions are in green text, deletions are in strikethrough red text. A separate Final version with all changes accepted is available in this publication.

International Standard IEC 60068-2-58 has been prepared by IEC technical committee 91: Electronics assembly technology.

This fourth edition constitutes a technical revision.

This edition includes the following significant technical changes with respect to the previous edition:

- the addition of Sn-Bi low temperature solder alloy;
- the addition of several reflow test conditions in Table 7 – Resistance to soldering heat – Test conditions and severity, reflow method;
- introduction of reflow test method for Test Td₃: Dewetting and resistance to dissolution of metallization;
- implementation of guidance for the choice of a test severity in Clause B.3.

This publication has been drafted in accordance with the ISO/IEC Directives, Part 2.

A list of all parts in the IEC 60068, published under the general title *Environmental testing*, can be found on the IEC website.

The committee has decided that the contents of the base publication and its amendment will remain unchanged until the stability date indicated on the IEC web site under "<http://webstore.iec.ch>" in the data related to the specific publication. At this date, the publication will be

- reconfirmed,
- withdrawn,
- replaced by a revised edition, or
- amended.

IMPORTANT – The 'colour inside' logo on the cover page of this publication indicates that it contains colours which are considered to be useful for the correct understanding of its contents. Users should therefore print this document using a colour printer.

ENVIRONMENTAL TESTING –

Part 2-58: Tests – Test Td: Test methods for solderability, resistance to dissolution of metallization and to soldering heat of surface mounting devices (SMD)

1 Scope

This part of IEC 60068 outlines test Td, applicable to surface mounting devices (SMD).

This ~~standard~~ document provides procedures for determining the solderability, **resistance to dissolution of metallization** and resistance to soldering heat of devices in applications using solder alloys, which are eutectic or near eutectic tin lead (Pb), or lead-free alloys.

The procedures use either a solder bath or reflow method and are applicable only to specimens or products designed to withstand short term immersion in molten solder or limited exposure to reflow systems.

The solder bath method is applicable to SMDs designed for flow soldering and SMDs designed for reflow soldering when the solder bath (dipping) method is appropriate.

The reflow method is applicable to the SMD designed for reflow soldering, to determine the suitability of SMDs for reflow soldering and when the solder bath (dipping) method is not appropriate.

The objective of this standard is to ensure solderability of component lead or termination. In addition, test methods are provided to ensure that the component body can resist against the heat load to which it is exposed during soldering.

This standard covers tests Td₁, Td₂ and Td₃ as listed below:

Number of Td	Test	Method
Td ₁	Solderability of terminations	Method 1: Solder bath Method 2: Reflow
Td ₂	Resistance to soldering heat	Method 1: Solder bath Method 2: Reflow
Td ₃	Dewetting and resistance to dissolution of metallization	Method 1: Solder bath Method 2: Reflow

NOTE 1 For specific components other test methods may exist.

NOTE 2 Test Td does not apply to printed wiring board (PWB), see IEC 61189-3.

NOTE 3 Specific through-hole devices (where the device supplier has specifically documented support for reflow soldering) are also included in this standard.

2 Normative references

The following documents, in whole or in part, are normatively referenced in this document and are indispensable for its application. For dated references, only the edition cited applies. For undated references, the latest edition of the referenced document (including any amendments) applies.

IEC 60068-1, *Environmental testing – Part 1: General and guidance*

IEC 60068-2-20:2008, *Environmental testing – Part 2-20: Tests – Test T: Test methods for solderability and resistance to soldering heat of devices with leads*

IEC 60194, *Printed board design, manufacture and assembly – Terms and definitions*

IEC 61190-1-1, *Attachment materials for electronic assemblies – Part 1-1: Requirements for soldering fluxes for high-quality interconnections in electronics assembly*

IEC 61190-1-2:2014, *Attachment materials for electronic assembly – Part 1-2: Requirements for solder pastes for high-quality interconnections in electronics assembly*

IEC 61190-1-3:2007, *Attachment materials for electronic assembly – Part 1-3: Requirements for electronic grade solder alloys and fluxed and non-fluxed solid solders for electronic soldering applications*

IEC 61190-1-3:2007/AMD1:2010

IEC 61191-2, *Printed board assemblies – Part 2: Sectional specification – Requirements for surface mount soldered assemblies*

IEC 61249-2-22, *Materials for printed boards and other interconnecting structures – Part 2-22: Reinforced base materials clad and unclad – Modified non-halogenated epoxide woven E-glass laminated sheets of defined flammability (vertical burning test), copper-clad*

IEC 61249-2-35, *Materials for printed boards and other interconnecting structures – Part 2-35: Reinforced base materials, clad and unclad – Modified epoxide woven E-glass laminate sheets of defined flammability (vertical burning test), copper-clad for lead-free assembly*

IEC 61760-1, *Surface mounting technology – Part 1: Standard method for the specification of surface mounting components (SMDs)*

ISO 9454-2:1998, *Soft soldering fluxes – Classification and requirements – Part 2: Performance requirements*

3 Terms and definitions

For the purposes of this document, the terms and definitions given in IEC 60068-1, IEC 60068-2-20, IEC 60194, and the following apply.

3.1 solderability

ability of the termination or electrode of the SMD to be wetted by solder at the temperature of the termination or electrode, which is assumed to be the lowest temperature in the soldering process, within the applicable temperature range of the solder alloy

3.2 resistance to soldering heat

ability of the component to withstand the highest temperature stress in terms of temperature gradient, peak temperature and duration of the soldering process, within the applicable temperature range of the solder alloy

3.3 flow soldering

wave, drag or dip soldering process where the product is brought into contact with molten solder in order to attach electronic components to the interconnecting surface

3.4 reflow soldering

joining of surfaces that have been tinned and/or have solder between them, placing them together, heating them until the solder flows, and allowing the surface and the solder to cool in the joined position

3.5 wetting

formation of an adherent coating of solder on a surface indicated by a small contact angle

3.6

dewetting

retraction of molten solder on a solid area that it has initially wetted

Note 1 to entry: In some cases an extremely thin film of solder may remain. As the solder retracts the contact angle increases.

3.7

non-wetting

inability to form an adherent coating of solder on a surface indicated by a contact angle greater than 90°

3.8

dissolution of metallization

process of dissolving metal, usually by introduction of chemicals

3.9

pinhole

small hole that penetrates from the surface of a solder to base material

4 Grouping of soldering processes and related test severities

The melting temperatures of lead-free solder alloys selected for industrial processes are significantly different from those for Sn-Pb solder alloy. Moreover, the melting temperatures of lead-free solder alloys are different from each other but can be clustered in groups.

The following groups of soldering processes as indicated in Table 1, are given as a guideline to select the severities for the wetting and resistance tests against the specified soldering heat:

Table 1 – Grouping of soldering processes and typical test severities – Overview

Process temperature group ^a		1 Low	2 Medium	3 Medium-high	4 High
Typical solder alloy group		Sn-Bi	Sn-Pb	Sn-Ag-Cu	Sn-Cu
Typical process temperature	Flow	–	235 °C to 250 °C	250 °C to 260 °C	250 °C to 260 °C ^c
	Reflow	170 °C to 210 °C	210 °C to 240 °C	235 °C to 250 °C	–
Test method	Test property	Temperature / Duration			
Solder bath	Solderability (6.5)	175 °C / 3 s	235 °C / 2 s	245 °C / 3 s	250 °C / 3 s
	Resistance to soldering heat (7.5)	230 °C / 10 s	260 °C / 5 s	260 °C / 5 s	260 °C / 10 s
			260 °C / 10 s	260 °C / 10 s	
	Dewetting (8.2)	–	260 °C / 5 s	–	–
260 °C / 10 s			–	–	
Resistance to dissolution of metallization (8.2)	–	260 °C / 30 s			
Reflow	Solderability ^b (6.6)	170 °C / 10 s	215 °C / 10 s	235 °C / 10 s	–
	Resistance to soldering heat (7.6)	–	235 °C / 20 s	230 °C / 30 s	–
				245 °C / 30 s	
	Dewetting (8.2)	–	235 °C / 20 s	250 °C / 30 s	–
260 °C / 30 s					
^a Refer to the appropriate subclauses for the detailed test conditions. ^b Measured at the solder joint. ^c 255 °C to 265 °C may be an applicable soldering temperature range for boards with high thermal demand.					

The following statements shall be applied in Table 1;

- Flow soldering applies to both wave soldering and dip soldering.
- Typical process temperatures for flow soldering are identical to the solder temperature. Typical process temperatures for reflow soldering are the terminal and top surface temperature of the SMDs.
- The basic solder alloys listed in Table 1 present tin-lead solder and compositions that are currently preferred for lead-free soldering processes. However, other solder alloys when matching with the specified group should not be excluded.

5 Test equipment

5.1 Solder bath

As given in IEC 60068-2-20:2008, 5.2.1, the solder bath shall be not less than 40 mm in depth and not less than 300 ml in volume.

In case of high thermal capacity components, the volume of the solder bath shall be given by the relevant specification.

The material of the solder bath container shall be resistant to the liquid solder alloy.

5.2 Reflow equipment

As long as the test conditions are fulfilled, any reflow equipment may be used. The following two methods are preferred:

- g) forced gas convection;
- h) vapour phase.

NOTE 1 Forced gas convection is preferred, including infrared assistance.

NOTE 2 In case of vapour phase soldering, a specific vapour creating liquid is necessary for each test temperature.

6 Test Td₁: Solderability of terminations

6.1 Object and general description of the test

Test Td₁ provides two different test methods to determine the solderability of the metallized end cap terminations and metallic terminations which meets the applicable solder joint requirements of IEC 61191-2 using each of the soldering methods specified in IEC 61760-1.

- Method 1: Solder bath
- Method 2: Reflow

The test method to be used shall be prescribed in the relevant specification.

NOTE 1 The solder bath method is the one that simulates most closely the soldering procedures of flow soldering and similar soldering processes where the heat is applied directly through conduction from a molten solder.

NOTE 2 The reflow method is the one that simulates most closely the soldering procedures of reflow soldering processes, like forced gas convection or vapour phase, where the heat is applied by gas convection or vapour condensation.

6.2 Specimen preparation

The surface to be tested shall be in the "as received" condition and needs to be shielded from any kind of contamination, e.g. it shall not be subsequently touched by fingers.

The specimens shall not be cleaned prior to the application of a solderability test. If required by the relevant specification, the specimens may be degreased by immersion in a neutral organic solvent at room temperature.

6.3 Accelerated ageing

When accelerated ageing is prescribed by the relevant specification, one of the methods of IEC 60068-2-20:2008, 4.1.4 shall be used.

6.4 Initial measurements

The specimens shall be visually examined and, if required by the relevant specification, electrically and mechanically checked.

6.5 Method 1: Solder bath

6.5.1 Solder bath

See 5.1.

6.5.2 Solder and flux

The solder alloy shall be selected from Table 2, unless otherwise prescribed by the relevant specification.

Table 2 – Solder alloy and flux for test Td₁

Process temperature group	Solder alloy ^a and flux
1	Sn42Bi58 ^b
2	Sn60Pb40A or Sn63Pb37A
3	Sn96,5Ag3Cu,5
4	Sn99,3Cu,7
^a Solder alloy designations and tolerance of composition according to IEC 61190-1-3:2007 and Amendment 1:2010, Annex B. ^b Activated with 0,2 % chloride.	

The flux shall consist of 25 % mass fraction of colophony in 75 % mass fraction of 2-propanol (isopropanol) or ethyl alcohol (as specified in IEC 60068-2-20:2008, Annex B). Preferably the flux activity should conform with the “low (<0,01)” level L0, corresponding to a halide mass fraction of <0,01 % (Cl, Br, F) (see IEC 61190-1-1).

If non-activated flux is inappropriate, the relevant specification may prescribe the use of the above flux with the addition of diethylammonium chloride (analytical reagent grade) of a mass fraction of 0,2 % or 0,5 % chloride (expressed as free chlorine based on the colophony content), see Table 2.

6.5.3 Test procedure and conditions

6.5.3.1 Specimen

A specimen shall not be used for more than one test.

6.5.3.2 Clamping

The specimen shall be placed in a stainless steel clip as shown in Figure 1, where the cross sectional area of that clip shall not exceed the smallest cross sectional area of the specimen, unless otherwise prescribed by the relevant specification. No part of the clip jaws shall make contact with the areas to be examined. The specimen shall remain in the clip while being fluxed and dipped in the solder.

NOTE A clip with a thermal capacity of its dipped part significantly exceeding the thermal capacity of the specimen may lead to a decrease of the local bath temperature next to the specimen and thereby to an increase of the effective severity of this test.

6.5.3.3 Fluxing

The specimen shall be completely immersed in flux and withdrawn slowly, unless otherwise prescribed by the relevant specification. Any excess flux shall be removed by contact with absorbent paper.

6.5.3.4 Solder immersion

If the preheating is prescribed by the relevant specification, the specified duration and temperature shall be applied immediately prior to the immersion of the specimen in the solder bath, ~~unless otherwise prescribed by the relevant specification.~~

The oxide film on the solder bath shall be skimmed off immediately before immersion.

The immersion and withdrawal speed shall be in the range of 20 mm/s to 25 mm/s.

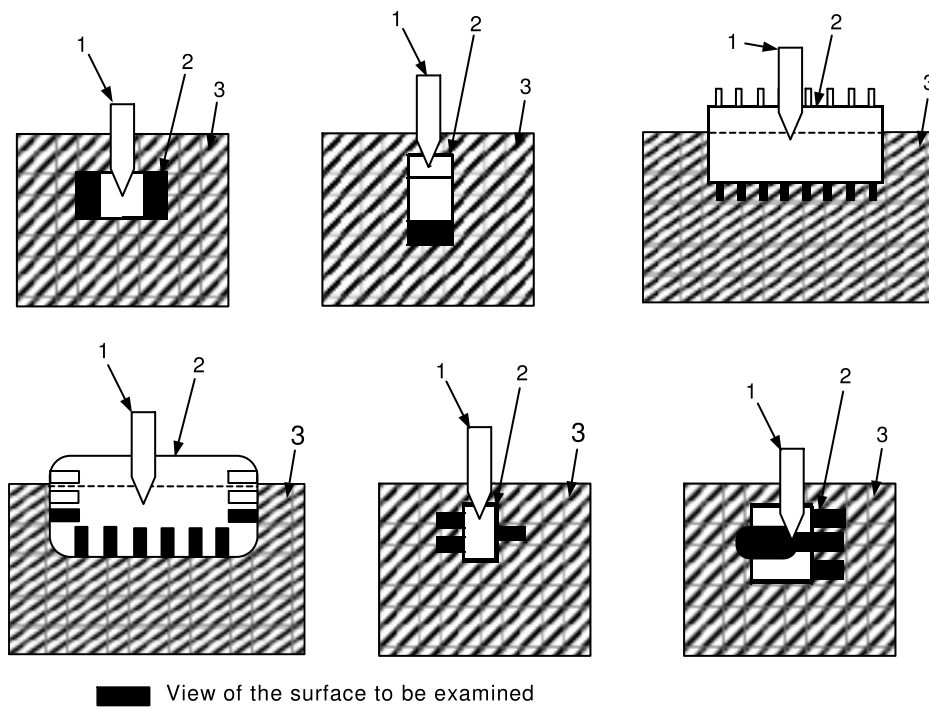

IEC

Key

- 1 Clip
- 2 Specimen
- 3 Solder

The immersion method may not be applicable for high thermal capacity components. The method to be applied for such components shall be given in the relevant specification.

Figure 1 – Examples of immersion attitudes

Two attitudes of immersion are standardized:

Attitude A: For most specimens, the areas to be examined shall be immersed not less than 2 mm below the solder meniscus (but not to a greater depth than necessary; see Figure 1) with the seating plane vertical.

Attitude B: For certain specimens (see B.3.4), the specimen may be floated on the solder.

Attitude A shall be applied, if the relevant specification does not prescribe an attitude to be used.

6.5.3.5 Test conditions

The duration and temperature of immersion shall be selected from Table 3, unless otherwise prescribed by the relevant specification.

Table 3 – Solderability – Test conditions and severity, solder bath method

Group	Alloy name	Test conditions and severity ^a	
		Temperature	Time
1	Sn42Bi58 (activated flux, 0,2 % chloride)	(175 ± 3) °C	(3 ± 0,5) s
2	Sn60Pb40A or Sn63Pb37A	(215 ± 3) °C	(3 ± 0,2) s
		(235 ± 3) °C	(2 ± 0,2) s
3	Sn96,5Ag3Cu,5	(245 ± 3) °C	(3 ± 0,3) s
4	Sn99,3Cu,7	(250 ± 3) °C	(3 ± 0,3) s

^a For components having a high thermal capacity the relevant specification may prescribe an extension of the immersion time up to (10 ± 1) s.

6.6 Method 2: Reflow

6.6.1 Reflow equipment

See 5.2.

6.6.2 Solder paste

Solder paste shall be as in Table 4, unless otherwise prescribed by the relevant specification.

Table 4 – Solder paste specification

Group	Alloy name ^a	Flux classification ^b		Powder size type ^c	Nominal metal content, mass fraction %
		IEC	ISO		
1	Sn42Bi58	ROL0	1.1.1	3	90
2	Sn60Pb40A or Sn63Pb37A	ROL0	1.1.1	3	90
3	Sn96,5Ag3Cu,5	ROL0	1.1.1	3	88
4	–	–	–	–	–

^a Solder alloy designations and tolerance of composition according to IEC 61190-1-3:2007 and Amendment 1:2010, Annex B.
^b Refer to IEC 61190-1-1 or ISO 9454-2 for details.
^c Refer to IEC 61190-1-2:2014, Table 2. Any other powder size should be prescribed in the relevant specification.

6.6.3 Test substrates

The test substrate shall consist of an unmetallized and non-wettable (no tracks or lands) piece of ceramic (alumina 90 % to 98 %) or epoxide woven E-glass laminated circuit board as defined, for example, in IEC 61249-2-22 or IEC 61249-2-35.

For the solderability test, the test substrate should not have solder lands, as a visual examination of the bottom side of the termination/electrode is required. See Annex A.

Dimensional details and the number of sample(s) to be tested shall be given in the relevant specification.

6.6.4 Test procedure

6.6.4.1 Specimens

A specimen shall not be used for more than one test.

6.6.4.2 Application of solder paste

The solder paste shall be applied to the test substrate by screen or stencil printing, dispensing or pin transfer.

The area (size) to be printed, and thus the amount of solder paste deposit, shall be specified in the relevant specification. When solder paste is applied by dispensing or pin transfer, the volume shall be adjusted so that a comparable solder volume can be achieved.

NOTE The thickness of the solder deposit is in the range from 60 μm to 250 μm .

6.6.4.3 Placement of specimens

After printing, the terminations of the specimen shall be placed on the solder paste. The placement procedure (for example depth of penetration) shall be prescribed in the relevant specification.

6.6.5 Reflow temperature profile for Test Td_1

As a minimum, the following parameters shown in Figure 2 shall be specified for the reflow temperature profile.

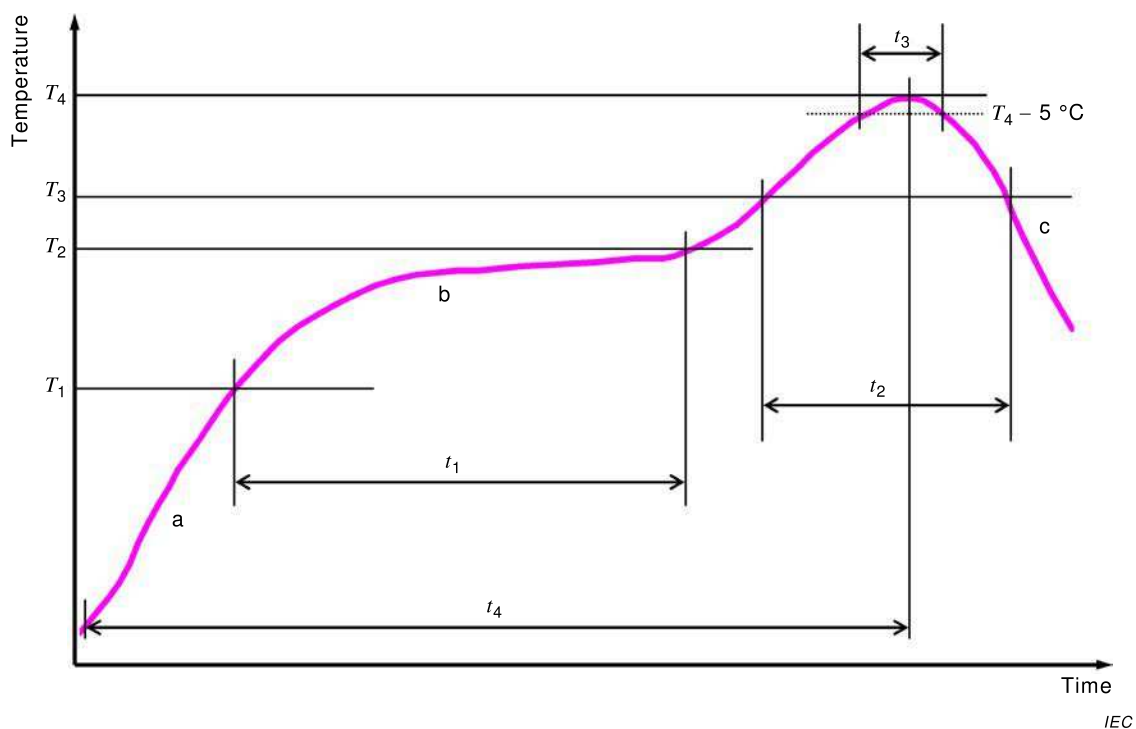

Key

- T_1 Minimum preheating temperature
- T_2 Maximum preheating temperature
- T_3 Liquidus temperature
- T_4 Peak temperature
- t_1 Preheating duration
- t_2 Time above liquidus temperature
- t_3 Time above $(T_4 - 5\text{ °C})$
- t_4 Time to T_4
- a The temperature gradient of the increasing slope shall not exceed 3 K/s.
- b Preheat area.
- c The temperature gradient of the decreasing slope shall not exceed 6 K/s.

Figure 2 – Reflow temperature profile for solderability

The temperature shall be measured at the specimen termination, unless otherwise prescribed by the relevant specification.

6.6.6 Test conditions

The parameters for the temperature profile shall be selected from Table 5, unless otherwise prescribed by the relevant specification.

Table 5 – Solderability – Test conditions – Method 2: Reflow

Group	Solder alloy	T_1 °C	T_2 °C	t_1 s	T_3 °C	t_2 s	T_4^a °C	t_3^b s
1	Sn42Bi58	100 ± 5	130 ± 5	60 to 120	138	40 ± 5	170	10
2	Sn63Pb37A Sn60Pb40A	100	150	60 to 120	183	40 ± 5	215	10
3	Sn96,5Ag3Cu,5	150	180	60 to 120	217	40 ± 5	235	10
4	Not applicable							
^a Peak temperature (T_4) is defined as minimum for acceptance testing and maximum for qualification testing. ^b Time above ($T_4 - 5$ °C) is defined as minimum for acceptance testing and maximum for qualification testing.								

7 Test Td_2 : Resistance to soldering heat

7.1 Object and general description of the test

Test Td_2 provides two different test methods to evaluate the soldering heat resistance of SMD.

- Method 1: Solder bath (Not applicable to the component designed for reflow soldering only)
- Method 2: Reflow

The test method to be used shall be indicated in the relevant specification.

NOTE 1 The solder bath method is the one that simulates most closely the soldering procedures of flow soldering and similar soldering process where the heat is applied directly through conduction from a molten solder.

NOTE 2 The reflow method is the one that simulates most closely the soldering procedures of reflow soldering processes, like forced gas convection or vapour phase, where the heat is applied by gas convection or vapour condensation.

NOTE 3 The relevant specification may specify a reflow soldering simulation test without application of solder paste (e.g. see IEC 60749-20 for semiconductor devices).

7.2 Specimen preparation

The surface to be tested shall be in the "as received" condition and needs to be shielded from any kind of contamination, e.g. shall not be subsequently touched by fingers.

If required by the relevant specification, the specimen may be degreased by immersion in a neutral organic solvent at room temperature.

7.3 Preconditioning

In case of moisture sensitive devices (MSD) pre-drying may be needed.

NOTE 1 When moisture sensitive devices (MSD) are tested, moisture soak can be considered to determine the influence of absorbed moisture to the resistance against soldering heat under worst case conditions.

NOTE 2 Examples for suitable soak procedures may be found in IEC 60749-20, or IEC 61760-4.

7.4 Initial measurements

The specimens shall be visually examined and, if required by the relevant specification, electrically and mechanically checked.

7.5 Method 1: Solder bath

7.5.1 Solder bath

See 5.1.

7.5.2 Solder and flux

For the resistance to the soldering heat test, any alloys may be used, provided they are completely liquid at the required temperature.

The flux shall consist of a mass fraction of 25 % of colophony in a mass fraction of 75 % of 2-propanol (isopropanol) or ethanol (ethyl alcohol), as specified in IEC 60068-2-20:2008, Annex B, activated by the addition of diethylammonium chloride (analytical reagent grade), of a mass fraction of 0,5 % chloride (expressed as free chlorine based on the colophony content).

Information concerning the used flux type shall be given in the product detail specification.

7.5.3 Test procedure and conditions

7.5.3.1 Specimens

A specimen shall not be used for more than one test.

7.5.3.2 Clamping

The specimen shall be placed in a stainless steel clip as shown in Figure 1, where the cross sectional area of that clip shall not exceed the smallest cross sectional area of the specimen, unless otherwise prescribed by the relevant specification. No part of the clip jaws shall make contact with the areas to be examined. The specimen shall remain in the clip while being fluxed and dipped in the solder.

NOTE A clip with a thermal capacity of its dipped part significantly exceeding the thermal capacity of the specimen may lead to a decrease of the local bath temperature next to the specimen and thereby to a decrease of the effective severity of this test.

7.5.3.3 Fluxing

The specimen shall be completely immersed in flux and withdrawn slowly, unless otherwise prescribed by the relevant specification. Any excess flux shall be removed by contact with absorbent paper.

7.5.3.4 Solder immersion

If preheating is prescribed by the relevant specification, the specified duration and temperature shall be applied immediately prior to the immersion of the specimen in the solder bath.

The oxide film on the solder bath shall be skimmed off immediately before immersion.

The immersion and withdrawal speed shall be in the range of 20 mm/s to 25 mm/s.

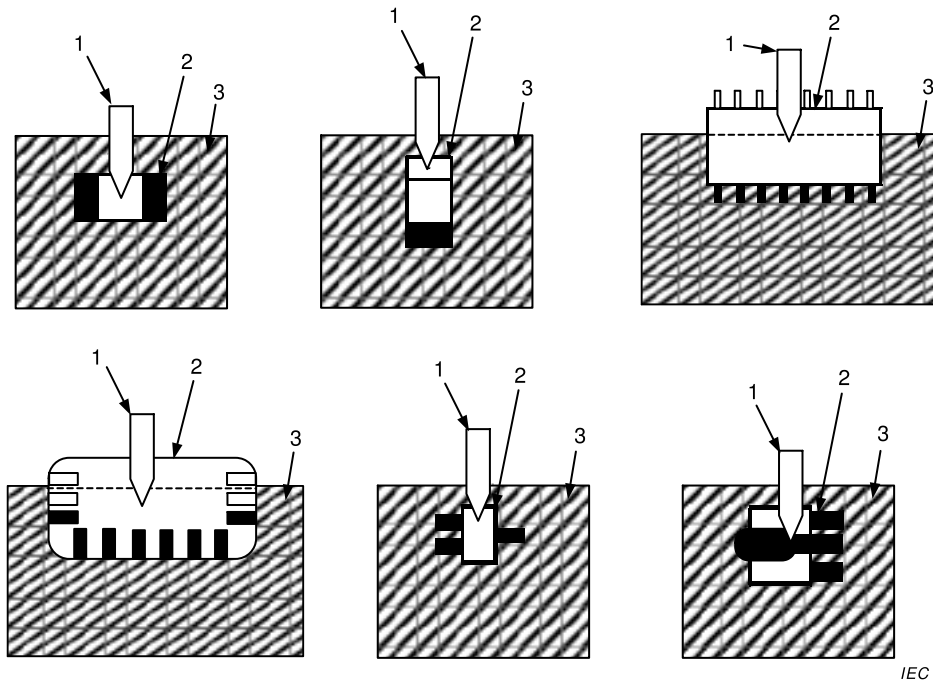

Key

- 1 Clip
- 2 Specimen
- 3 Solder

The methods shown may not be applicable to high thermal capacity components. Immersion method for high thermal capacity components shall be given in the relevant specification.

Figure 3 – Examples of immersion attitude

Two attitudes of immersion are standardized:

Attitude A: For most specimens, the areas to be examined shall be immersed not less than 2 mm below the solder meniscus (but not to a greater depth than necessary; see Figure 3) with the seating plane vertical.

Attitude B: For certain specimens (see B.3.4), the specimen may be floated on the solder.

If the relevant specification does not mention the attitude, attitude A shall be adopted.

7.5.3.5 Test conditions – Method 1: Solder bath

The duration and temperature of immersion shall be selected from Table 6, unless otherwise prescribed by the relevant specification.

**Table 6 – Resistance to soldering heat –
 Test conditions and severity, solder bath method**

Group	Alloy composition ^a	Test conditions and severity	
1	Sn42Bi58	(230 ± 3) °C	(10 ± 1) s
2	Sn60Pb40A or Sn63Pb37A	(260 ± 5) °C	(5 ± 1) s
			(10 ± 1) s
3	Sn96,5Ag3Cu,5	(260 ± 5) °C ^b	(5 ± 1) s
			(10 ± 1) s
4	Sn99,3Cu,7	(260 ± 5) °C ^b	(10 ± 1) s

^a Alloy compositions given here are for information only and do not state any prescription for specific alloys to be used in this test, see 7.5.2.

^b Certain soldering methods may require the higher severity of (270 ± 3) °C for (5 ± 0,5) s or the more severe condition of (10 ± 1) s. Such conditions should be provided by the detail specification or agreed between the trading partners.

7.6 Method 2: Reflow

7.6.1 Reflow equipment

See 5.2.

7.6.2 Solder paste

Solder paste is normally not required for the resistance to soldering heat test.

7.6.3 Test substrates

If required, the test substrate shall consist of an unmetallized and non-wettable (no tracks or lands) piece of ceramic (alumina 90 % to 98 %) or epoxide woven E-glass laminated circuit board as defined, for example, in IEC 61249-2-22 or IEC 61249-2-35.

For the resistance to soldering heat test, the test substrate should not have solder lands, as a visual examination of the bottom side of the component is required. See Annex A.

Dimensional details and the number of sample(s) to be tested shall be given in the relevant specification.

This test does not cover additional stresses to the test specimen by circuit boards. The mounting to test substrates before testing shall be described by the relevant specification.

7.6.4 Test procedure and conditions

7.6.4.1 Specimens

A specimen shall not be used for more than one test. The specimen may be tested with or without solder paste, as required by the relevant specification.

7.6.4.2 Application of solder paste

If required, the solder paste shall be applied to the test substrate by screen or stencil printing, dispensing or pin transfer as specified in the relevant specification. In this case the area (size) to be printed and the thickness of the solder paste deposit shall be specified in the relevant specification. When solder paste is applied by dispensing or pin transfer, the volume shall be adjusted so that a comparable solder volume can be achieved.

7.6.4.3 Placement of specimens

As applicable, after printing, the terminations of the specimen shall be placed on the solder paste or the substrate. The placement procedure (for example depth of penetration) shall be prescribed in the relevant specification.

7.6.4.4 Reflow temperature profile

As a minimum, the following parameters shown in Figure 4 shall be specified for the reflow temperature profile.

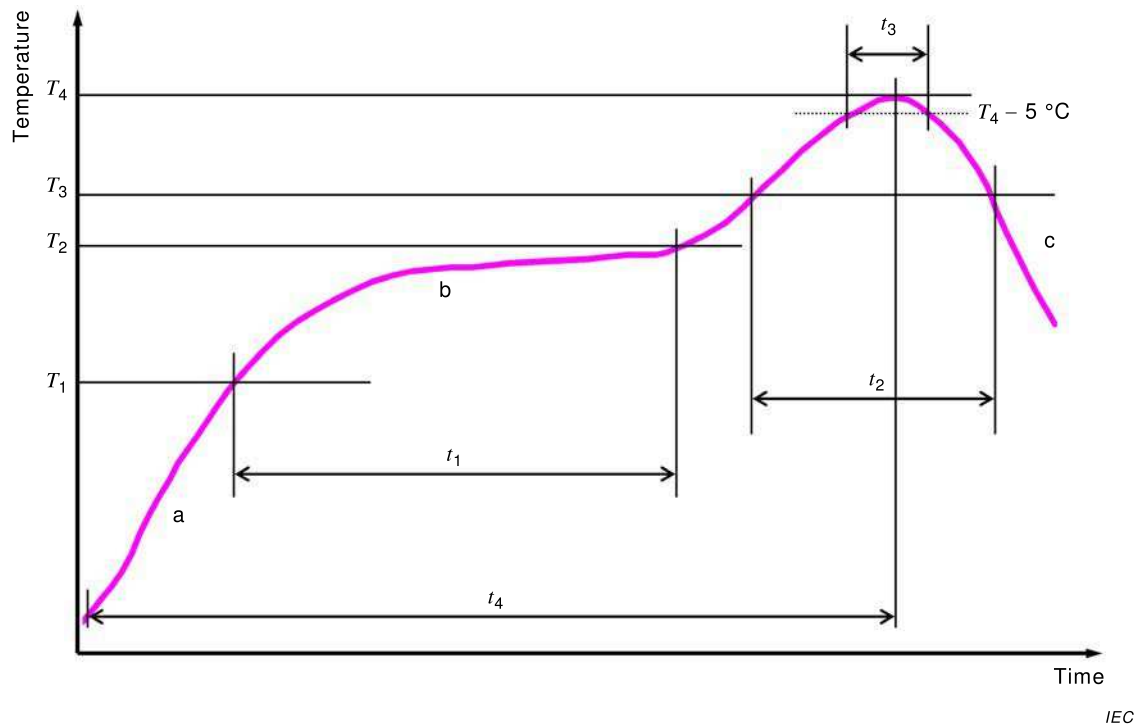

T_1 Minimum preheating temperature

T_2 Maximum preheating temperature

T_3 Liquidus temperature

T_4 Peak temperature

t_1 Preheating duration

t_2 Time above liquidus temperature

t_3 Time above $(T_4 - 5 \text{ °C})$

t_4 Time to T_4

a The temperature gradient of the increasing slope shall not exceed 3 K/s.

b Preheat area

c The temperature gradient of the decreasing slope shall not exceed 6 K/s.

Figure 4 – Reflow temperature profile for resistance to soldering heat

The temperature shall be measured at the specimen's top body surface (peak package body temperature), unless otherwise prescribed by the relevant specification.

The reflow temperature profile for resistance to soldering heat test shall be as specified in Table 7, unless otherwise prescribed by the relevant specification.

NOTE A forced gas convection oven is recommended to ensure reproducibility of the reflow temperature profile.

The number of test cycles shall be a minimum of one and a maximum of three, and shall be specified in the relevant specification, unless otherwise prescribed by the relevant specification. The recovery period between two successive cycles shall be the time it takes until the temperature of the specimen drops below 50 °C.

**Table 7 – Resistance to soldering heat –
 Test conditions and severity, reflow method**

Group	Alloy name	T_1 °C	T_2 °C	t_1^f s	T_3 °C	t_2^g s	T_4^a °C	$t_3^{b,a}$ s	t_4 s
1	Sn42Bi58				138				
2	Sn63Pb37A Sn60Pb40A	100	150	60 to 120	183	30 to 60 ^e 60 to 150	215 235	10 ± 1 20 ± 1 30 ± 1 40 ± 1	360 max
3	Sn96,5Ag3Cu,5	150	200		217		220 to 235 ^c	20 to 40 ^c	480 max
							230 to 260 ^e	5 max ^e 10 max ^e	
					245 250 260	20 ± 1 30 ± 1 ^d			
<p>^a The combination of temperature and time is determined by the thermal mass of the component and shall be given by the relevant specification. Further information how to determine applicable test conditions, see IEC TR 60068-3-12. Peak temperature (T_4) measured at the specimen's top body surface is defined as maximum for acceptance testing and minimum for qualification testing.</p> <p>^b Tolerance for time above ($T_4 - 5$ °C) is defined maximum as for acceptance testing and minimum for qualification testing.</p> <p>^c Components with high thermal mass may require this severity; details shall be provided by the relevant specification.</p> <p>^d A more severe t_3 of (40 ± 1) s is also in use for certain applications with high package density / high thermal mass PCB.</p> <p>^e Applicable for high thermal sensitivity.</p> <p>^f Depending on the thermal mass of the components, the time t_1 may be extended.</p> <p>^g The time t_2 depends on the thermal mass of the components.</p>									

8 Test Td₃: Dewetting and resistance to dissolution of metallization

8.1 Object and general description of the test

Test Td₃ provides a test method to evaluate the loss of wetting ability of a terminal surface during soldering (dewetting), or the loss of solderable area of a terminal surface by dissolution of metallization.

- Method 1: Solder bath
- Method 2: Reflow

The test method to be used shall be indicated in the relevant specification.

NOTE Reflow test method to determine the dewetting

8.2 Specimen preparation

The surface to be tested shall be in the "as received" condition and needs to be shielded from any kind of contamination, e.g. shall not be subsequently touched by the fingers or otherwise contaminated.

If required by the relevant specification, the specimen may be degreased by immersion in a neutral organic solvent at room temperature.

In case of MSD pre-drying may need to be considered.

8.3 Initial measurements

The specimens shall be visually examined and, if required by the relevant specification, electrically and mechanically checked.

8.4 Method 1: Solder bath

8.4.1 Solder bath

See 5.1.

8.4.2 Solder and flux

See 7.5.2.

8.4.3 Test procedure and conditions

The duration and temperature of immersion shall be selected from Table 8, unless otherwise prescribed by the relevant specification.

If a total immersion time of 10 s is required because dewetting can occur slowly, this immersion shall be divided into two periods of 5 s each in order that any rapid dewetting is not masked by any subsequent re-wetting.

Guidance on the choice of severities, including those for lower grades of dissolution of metallization, is given in Clause B.3.

The speed of dewetting and dissolution of metallization depends on temperature, time and the combination of terminal surface material and solder alloy.

**Table 8 – Dewetting and resistance to dissolution of metallization –
Test conditions and severity, solder bath method**

Property tested	Severity		
	(260 ± 5) °C		
	(5 ± 0,5) s	(10 ± 1) s	(30 ± 1) s
Dewetting	X	X	
Resistance to dissolution of metallization			X
X" denotes 'applicable'.			

8.5 Method 2: Reflow

8.5.1 Reflow equipment

See 5.2.

8.5.2 Specimen

A specimen shall not be used for more than one test. The test applies only for specimens with a pin finish that will melt during the reflow process, this is not the case for, for example, NiPdAu pin finishes.

8.5.3 Solder paste

Solder paste is not required for this test.

8.5.4 Flux

Flux shall be used as described in Table 4, or as required in the relevant specification. It shall be applied by a brush on the termination of the tested component.

8.5.5 Reflow profile

Reflow profile as described in Figure 4 and Table 7 shall be applied, unless otherwise prescribed by the relevant specification.

8.5.6 Placement of the specimen

The specimens to be tested shall be fixed to a suitable substrate in a way, (e.g. with a high temperature double sided adhesive tape) that they will not move during the reflow test. The components shall be fixed upside down (on the tape), and the terminations shall show upwards, as demonstrated in Figure 5 and parallel to the carrier.

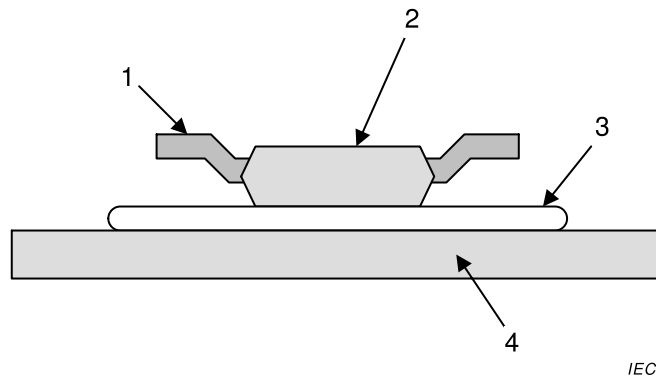

Key

- 1 Termination
- 2 Component (upside down)
- 3 High temperature double sided adhesive tape
- 4 Substrate

Figure 5 – Example for placement of a specimen to a test substrate

8.5.7 Application of the reflow profile

The selected reflow profile shall be applied once to the specimen on the carrier, in order to melt the termination finish.

8.5.8 Evaluation

Dewetting shall not exceed the criteria described in Clause ~~A.4~~ A.2.

Note that this test does not directly assess the dewetting but assesses the possibility of the dewetting.

9 Final measurements

9.1 Flux removal

Within 60 min of the test and after the specimen has been allowed to cool to room temperature, the flux residues shall be removed with a suitable solvent. After cooling, the specimen shall be removed from the substrate for inspection. Details of the removal procedure shall be given in the relevant specification.

9.2 Recovery conditions

The recovery conditions shall be prescribed in the relevant specification.

9.3 Evaluation

9.3.1 Wetting

9.3.1.1 General

The wetting shall be assessed visually under adequate light with a binocular microscope of a magnification in the range of 10× to 25×, using the photographs of component terminations in Clause A.1 to assist with the evaluation. The areas to be examined shall be prescribed in the relevant specification.

9.3.1.2 Metallized end cap terminations (rectangular or circular configuration)

The dipped or reflowed surface shall be covered with solder coating with no more than small amounts of scattered imperfections, such as pinholes or non-wetted or dewetted areas. These imperfections shall not be concentrated in one area. Additionally, for solder alloy containing lead, solder coating shall be smooth and bright.

9.3.1.3 Metallic terminations shorter than 6 mm (dimension “d” in Figure 6)

The following criteria apply where the specimen is tested in the “as-received” condition or after accelerated ageing.

a) Areas that form the joint (area “a” in Figure 6):

- 1) the underside of the termination foot (area “d” in Figure 6) and the convex side of the lower bend;
- 2) the side faces of the foot.

The highest quality is required in these areas. The dipped or reflowed surface shall be covered with solder coating with no more than small amounts of scattered imperfections such as pinholes, non-wetted or dewetted areas. These imperfections shall not be concentrated in one area. For solder alloy containing lead, the solder coating shall be smooth and bright.

b) The upper side of the termination (area “b” in Figure 6).

⊕ After the dipping test, the dipped surface shall show visible evidence of being wettable, as indicated by the presence of fresh solder. A homogeneous coating is not necessary here.

⊕c) Non-coated cut edges at the end of the termination and the termination above the lower bend (area “c” in Figure 6).

For these areas (“b”, “c” and “d”), no quality criterion of solder coating is given.

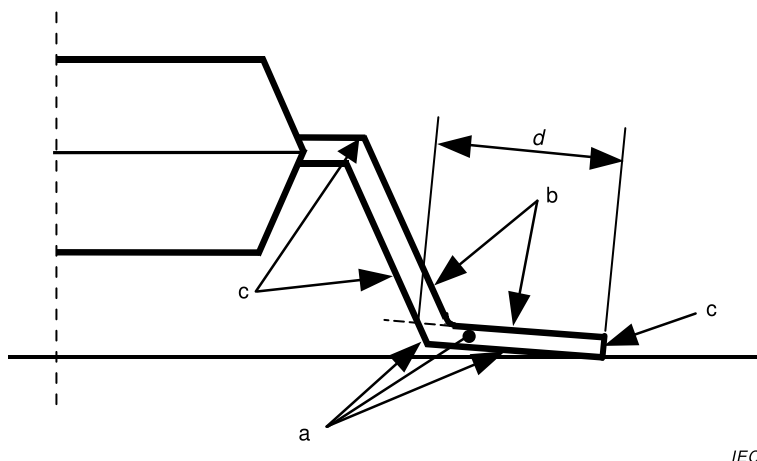

Figure 6 – Identification of areas on metallic termination

9.3.1.4 Other metallic terminations

The areas to be examined and criteria for evaluation shall be specified in the relevant specification.

9.3.2 Dewetting

If applicable, the criteria for wetting described in 9.3.1 shall also apply.

The dewetting shall be assessed visually under adequate light with a binocular microscope of magnification in a range of 10x to 100x.

9.3.3 Resistance to soldering heat

After testing for resistance to soldering heat, the specimen shall be electrically checked and visually examined in accordance with the relevant specification.

9.3.4 Resistance to dissolution of metallization

If applicable, the following criteria shall apply. If these criteria cannot be applied, they shall be prescribed in the relevant specification.

- a) Areas where metallization is lost during immersion shall not individually exceed 5 % of the total electrode area, and collectively shall not exceed 10 % of the total electrode area.
- b) The functional connection of the electrode to the interior of the specimen shall not be exposed.
- c) Where the metallization of the electrode extends over edges onto adjacent surfaces, loss of metallization on the edges shall not exceed 10 % of their total length.

10 Information to be given in the relevant specification

10.1 General

If this test is included in a specification, the following details shall be given insofar as they are applicable. Particular attention shall be given to items marked with an asterisk (*) as this information is mandatory.

10.2 Solderability

The following details shall be applied for solderability.

- a) Property to be tested *
- b) Applicable test method *
- c) Condition of preconditioning (if required) *
- d) For solder bath method
 - 1) Selected solder alloy ~~(solder bath method)~~ *
 - 2) Flux type ~~(solder bath method)~~ *
 - 3) Clamping, fluxing and solder immersion *
 - 4) Preheating ~~for solder bath method~~ *
 - 5) Attitude to be used ~~for bath test~~
 - 6) Solder temperature and duration *
- e) For reflow method
 - 1) Solder paste *
 - 2) Dimensional details of test substrate *
 - 3) Thickness of solder paste *
 - 4) Amount of solder paste
 - 5) Placement procedure
 - ~~6) Pre-heating for reflow~~
 - 6) Temperature profile *
 - 7) Temperature measurement point *
- ~~f) Number of test cycles for resistance to soldering heat if other than 1 cycle *~~
- f) Removal procedure
- g) Cleaning method
- h) Recovery conditions
- i) Areas of the terminations to be examined *

- j) Final inspection requirements and acceptance criteria *

10.3 Resistance to soldering heat, dewetting and resistance to dissolution of metallization

The following details shall be applied for resistance to soldering heat, dewetting and resistance to dissolution of metallization.

- a) Property to be tested *
- b) Applicable test method *
- c) Condition of preconditioning (if required) *
- d) For solder bath method
 - 1) Selected solder alloy ~~(solder bath method)~~ *
 - 2) Flux type ~~(solder bath method)~~ *
 - 3) Clamping, fluxing and solder immersion *
 - 4) Preheating ~~for solder bath method~~ *
 - 5) Attitude to be used ~~for bath test~~
 - 6) Solder temperature and duration *
 - 7) Number of test cycles if other than 1 cycle (for resistance to soldering heat) *
- e) For reflow method
 - 1) Solder paste (if required) *
 - 2) Dimensional details of test substrate (for resistance to soldering heat and if required) *
 - 3) Thickness of solder paste (if required) *
 - 4) Amount of solder paste (if required)
 - 5) Placement procedure (if required) *
 - ~~6) Pre-heating for reflow~~
 - 6) Temperature profile *
 - 7) Temperature measurement point *
 - 8) Number of test cycles for resistance to soldering heat ~~if other than 1 cycle~~ *
- f) Removal procedure
- g) Cleaning method
- h) Recovery conditions
- i) Areas of the terminations to be examined *
- j) Final inspection requirements and acceptance criteria *

Annex A (normative)

Criteria for visual examination

A.1 Evaluation of wetting

A.1.1 General

In various specifications, a complete or nearly complete coating with solder is often defined by the so-called 95 % requirement. The application of this requirement is often difficult when assessing specimens with metallized terminations or with short metallic terminations, especially when different parts of the termination are distinguished. Nevertheless, the same approach is followed here. ~~To help in the evaluation of wetting, the photographs in Figure A.1 have been reproduced on such a scale that the dimensions are reasonably comparable with the view obtained under a microscope, while ensuring that smaller details are still sufficiently clear.~~

~~A.1.1~~A.1.2 Evaluation of Criteria for wetting

Acceptable when 95 % or more area to be evaluated covered by an ideal solder coating with a dewetting area ~~shall be~~ is scattered and not concentrated in one area.

Figure A.1 comprises six examples illustrating the criteria for visual examination.

NOTE To help in the evaluation of wetting, the photographs in Figure A.1 have been reproduced on such a scale that the dimensions are reasonably comparable with the view obtained under a microscope, while ensuring that smaller details are still sufficiently clear.



Acceptable	Unacceptable
 <p style="text-align: right;">IEC</p> <p>Acceptable: ideal coating both on the foot and on the sides; the visible rim is not dewetted because there is no contact angle; the flux residues between body and termination have not been removed.</p>	 <p style="text-align: right;">IEC</p> <p>Unacceptable: more than 5 % dewetting on the toe; the bend is well coated</p>
 <p style="text-align: right;">IEC</p> <p>Acceptable: some spots of non-ideal coating on the surface are visible.</p>	 <p style="text-align: right;">IEC</p> <p>Unacceptable: more than 5 % dewetting of the foot is dewetted.</p>
 <p style="text-align: right;">IEC</p> <p>Acceptable: a few very small irregularities are visible.</p>	 <p style="text-align: right;">IEC</p> <p>Unacceptable: more than 5 % of the area not wetted.</p>
<p>NOTE The arrows indicate imperfections (acceptable or unacceptable) referred to in Clause A.2.</p>	

Figure A.1 – Evaluation of wetting

A.1.2A.1.3 Evaluation of method 2 ($T_{d,1}$) Additional criteria for wetting, method 2

For method 2 (reflow), in addition to A.1.2, the following criteria shall be applied:

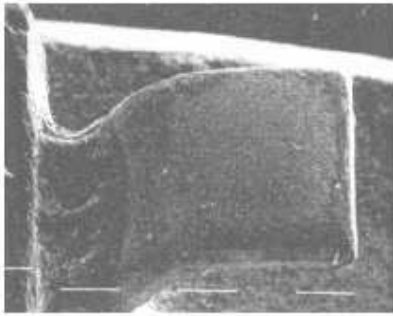
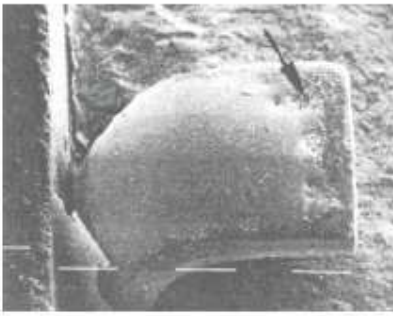
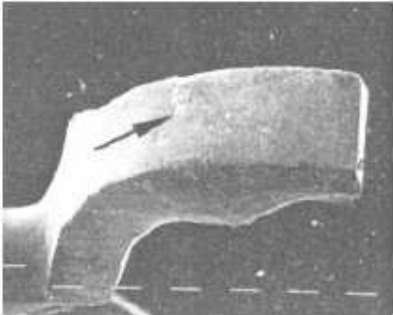
- solder balls at the pins or irregular solder accumulations are not allowed;
- the surface shall be homogenous without irregularities or damages.

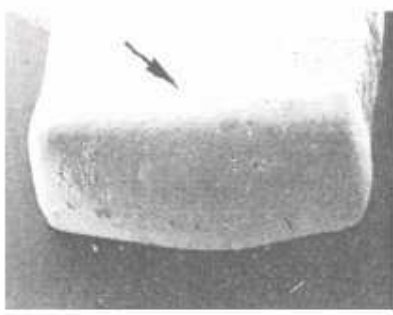
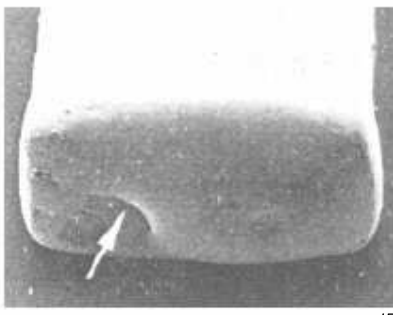
~~The results shall be documented in the test report including pictures.~~

A.2 Evaluation of dewetting, method 2 (Td_3)

Good example (no dewetting)

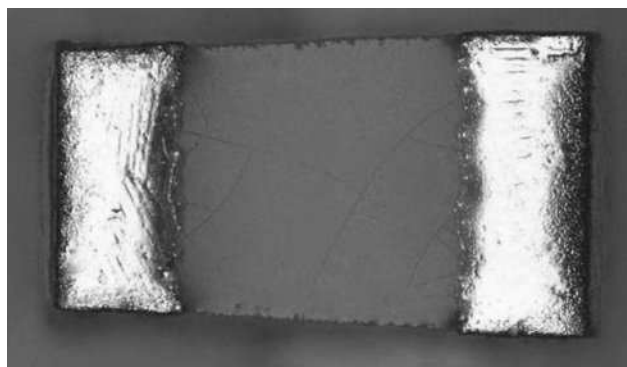

IEC

Negative example (dewetting > 5%)

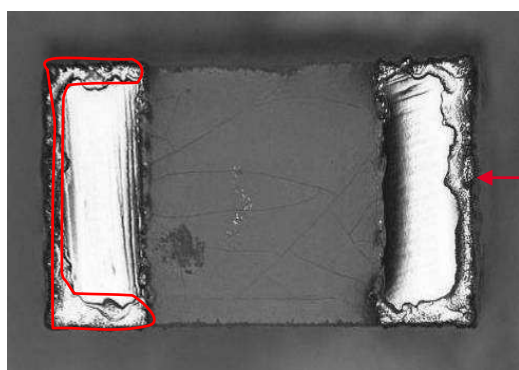

Bad edge covering

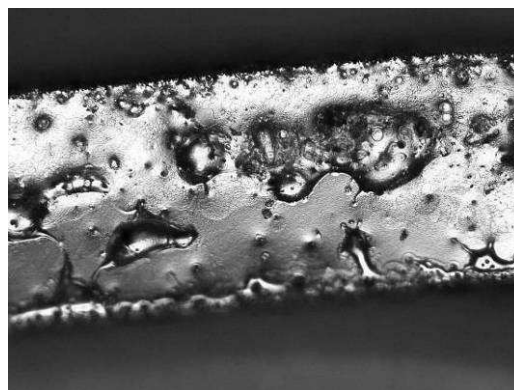
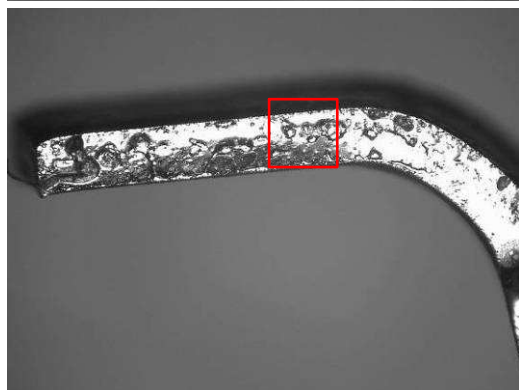

IEC

Figure A.2 comprises four examples illustrating the criteria for visual examination.

Good example (dewetting not present)	Negative example (dewetting > 5 %)
 <p data-bbox="699 562 735 584">IEC</p>	 <p data-bbox="1294 577 1331 600">IEC</p> <p data-bbox="999 622 1198 651">Bad edge covering</p>
 <p data-bbox="663 981 700 1003">IEC</p>	 <p data-bbox="1331 1496 1367 1518">IEC</p> <p data-bbox="986 1552 1214 1581">"Voids" dewetting</p>

Figure A.2 – Evaluation of dewetting

Annex B (informative)

Guidance

B.1 General

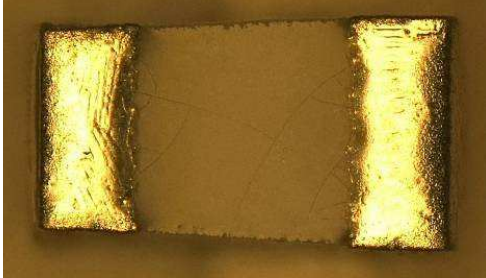
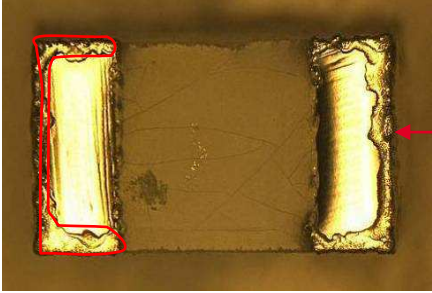
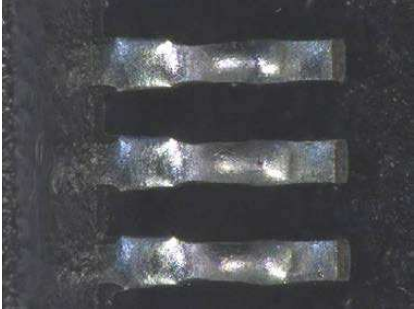
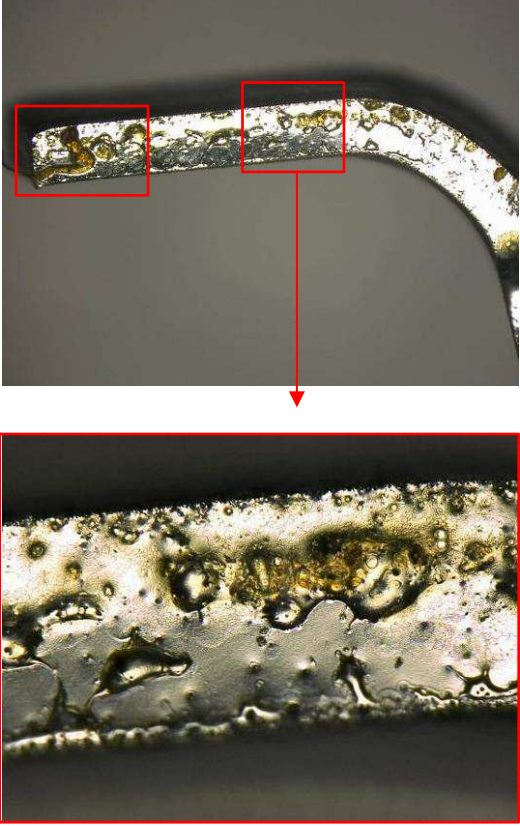
In principle, solderability testing should be quantitative and objective. During the preparation of this standard, consideration has been given to procedures which meet these requirements and these methods may be found in IEC 60068-2-69.

In choosing these conditions, consideration has been given to established procedures¹, as well as the solder bath dip or reflow test conditions already specified in IEC 60068-2-20 and IEC 60749-20.

For components intended for PCB bottom-side mounting and full body immersion during wave soldering, the solder bath method (attitude A) is the preferred condition. In such cases (e.g. for test Td_3), the correlation between the static solder dip conditions and the dynamic wave soldering conditions needs to be considered (i.e., wave soldering imposes more severe conditions on the component compared to dipping into a static solder bath), see B.3.5.

The reflow method has been included for SMDs that are intended for the reflow process only, or to determine the suitability of an SMD for reflow.

Some parts get damaged with reflow temperature profile. Therefore caution should be exercised when choosing reflow profiles and peak reflow temperatures. For example, a semiconductor device to ensure that the moisture sensitivity level (MSL) ratings of these parts are not exceeded (see IEC 60749-20 and IEC 61760-4²).

B.2 Limitations

B.2.1 In the case of specimens having terminations plated with pure tin, or another lead-free plating, there might be a mismatch between the results of the dip test in lead-tin solder bath, and the performance in practice using methods operating below the melting point of tin (for example vapour phase). The solution to this problem is not yet known. In such cases normal production methods or the reflow method may be used as a test procedure.

B.2.2 Excessive peak reflow temperatures initiate failures, which cause equipment failures under normal use conditions.

Solder dipping should only be used if data exists showing that correlation between the part junction temperature under wave solder and dipping is equivalent. In addition, data should exist showing the proper preheating for the correlation.

Preheating is extremely important to prevent damage to parts, especially to large volume packages. Preheating is part of a good process set-up.

B.3 Choice of severity

B.3.1 Test Td_1 : Solderability by solder bath method

The selection of time and temperature values from Table 3 depends on the thermal capacity of the components.

- a) Low thermal capacity and/or high heat resistance component

¹ These procedures have been established by TC 40 and TC 47, by IECQ: IEC Quality Assessment System for Electronic Components <http://www.iecq.org/index.htm> and by the AIE: International Association Of Electrical Contractors.

² To be published.

In Group 2, test condition 235 °C, 2 s is preferred for general components of low thermal capacity.

b) For high thermal capacity component

For components having a high thermal capacity the relevant specification may prescribe an extension of the immersion time up to (10 ± 1) s.

In case of high thermal capacity components with lead, attitude B (floating attitude) or using separated lead should be chosen to avoid drop in solder bath temperature.

B.3.2 Test Td₂: Resistance to soldering heat – Solder bath method

The selection of time and temperature values from Table 6 depends on the thermal capacity and thermal sensitivity of the components.

a) Low thermal capacity and/or high heat resistance component

In group 2 and 3, test condition 260 °C, 10 s is preferred for general components of low thermal capacity and high heat resistance.

b) For high thermal capacity component

Certain soldering methods may require higher severity of (270 ± 3) °C for $(5 \pm 0,5)$ s or the more severe condition of (10 ± 1) s. Such conditions should be provided by the detail specification or as agreed between the trading partners.

The solder bath method cannot be applied to certain large semiconductor packages designed for reflow soldering because the solder bath temperature is higher than the reflow soldering.

c) For low heat resistance component

In case of aluminium electrolytic capacitors with non-solid electrolyte, film dielectric capacitors and connectors, the solder bath method cannot be applied.

B.3.3 Test Td₂: Resistance to soldering heat –Reflow method

The selection of time and temperature values from Table 7 depends on the thermal capacity and thermal sensitivity of the components.

a) Low thermal capacity and/or high heat resistance component

The test conditions in Table B.1 are preferred for general components of low thermal capacity and high heat resistance.

Table B.1 – Test conditions

Group	Alloy name	T ₁ °C	T ₂ °C	t ₁ s	T ₃ °C	t ₂ s	T ₄ °C	t ₃ s	t ₄ s
1	Sn42Bi58				138				
2	Sn63Pb37A Sn60Pb40A	100	150	60 to 120	183	60 to 150	235	20 ± 1	360 max.
3	Sn96,5Ag3Cu,5	150	200		217		260	30 ± 1	480 max.

b) High thermal capacity component

In case of components with high thermal capacity, the temperatures and times given in Table 7 may not always be appropriate, e.g. T₄ cannot be achieved. In such a case t₁, t₂ and t₄ need to be determined such, that t₃ is achieved.

For plastic molded semiconductors, refer to IEC 60749-20.

c) For a low heat resistance component

Temperature and time need to be selected from Table 7 depending on the heat resistance of a component as given by the relevant specification.

For example, in case of aluminium electrolytic capacitors with non-solid electrolyte, the inner electrolyte temperature needs to be kept under the boiling point (e.g. 210 °C).

For information, see J-STD-075.

B.3.4 Immersion attitude

The selection of the immersion attitude in Figure 1 and Figure 3 depends on the thermal capacity of the components.

a) For solderability of the termination

When testing solderability of terminations, certain large flat specimens (for example ceramic chip carriers), if immersed in the solder bath, will absorb heat. In such cases, attitude B (the floating attitude) should be chosen by the detail specification. Discrimination between different sizes of specimens by varying the immersion time is not considered desirable.

b) For resistance to soldering heat

When testing resistance to soldering heat, certain large flat specimens (for example ceramic chip carriers), if immersed with the seating plane vertical, will not experience the thermal gradient across their thickness that they would in practical soldering. In such cases, attitude B (the floating attitude) should be chosen by the detail specification. Discrimination between different sizes of specimens by varying the immersion time is not considered desirable.

B.3.5 Test Td₃: Dewetting and resistance to dissolution of metallization for 30 s at 260 °C

See Table 8.

In wave soldering, the speed of dissolution of metallization is much greater than in a static dip. With wave, reflow or vapour-phase soldering, the specimen may be subjected to subsequent iron soldering for touch-up or repair. A rather long immersion at high temperature can therefore be specified for testing the resistance of the metallization to dissolution in molten solder.

The severities of dewetting and resistance to dissolution of metallization shall depend on the components electrode structure.

Annex C (normative)

Application of the test methods to through hole reflow soldering components (THR)

C.1 Solderability

The solderability of components intended for THR should be tested according IEC 60068-2-20, Test Ta, method 1, but according to the conditions given in Table C.1, which are different from those in IEC 60068-2-20 in order to reflect the conditions of reflow soldering. The relevant specification shall prescribe the preheating before immersion into the solder bath. A typical condition is keeping the test specimen in a distance of 10 mm above the solder bath surface for 30 s.

Table C.1 – Test conditions for solderability test

Solder	Test condition	Preheating
Sn60Pb40A	215 °C, (3 ± 0,3) s	optional
Sn96,5Ag3Cu,5	235 °C, (5 ± 0,5) s	recommended

C.2 Resistance to soldering heat

Test Td₂, method 2, reflow simulation without solder shall be used. The test conditions related to the respective soldering process group apply.

C.3 Dewetting

Test Td₃, method 2, reflow simulation without solder shall be used. The test conditions related to the respective soldering process group apply.

C.4 Criteria for evaluation

The criteria for evaluation shall be provided by the component specification.

Annex X (informative)

Cross reference for references to the prior revision of this specification

The revision of this sectional specification has resulted in a new structure. The following table provides a cross reference for all references to specific elements of the prior revision of this Sectional Specification.

IEC 60068-2-58:2004 3 rd edition Clause/Subclause	IEC 60068-2-58:201X 4 th edition Clause/Subclause	Notes
1	1	—
2	2	—
3	3	—
4	4	—
5	—	The prescriptions on preconditioning are allocated with the separate tests Td ₁ , Td ₂ , or Td ₃ , see below.
5.1	6.2 7.2 8.2	If applied to test Td ₁ If applied to test Td ₂ If applied to test Td ₃
5.2	6.3	—
5.3	7.3	—
6	—	The prescriptions on the solder bath method are allocated with the separate tests Td ₁ , Td ₂ , or Td ₃ , see below.
6.1	—	—
6.1.1	5.1	—
6.1.2	6.5.2 7.5.2 8.4.2	If applied to test Td ₁ If applied to test Td ₂ If applied to test Td ₃
6.1.3	6.5.2 7.5.2 8.4.2	If applied to test Td ₁ If applied to test Td ₂ If applied to test Td ₃
6.2	6.5.3 7.5.3 8.4.3	If applied to test Td ₁ If applied to test Td ₂ If applied to test Td ₃
7	—	The prescriptions on the solder reflow method are allocated with the separate tests Td ₁ , Td ₂ , or Td ₃ , see below.
7.1	—	—
7.1.1	5.2	—
7.1.2	6.6.2. 7.6.2 8.5.3	If applied to test Td ₁ If applied to test Td ₂ If applied to test Td ₃
7.1.3	6.6.3 7.6.3	If applied to test Td ₁ If applied to test Td ₂
7.2	6.6.4 7.6.4	If applied to test Td ₁ If applied to test Td ₂

IEC 60068-2-58:2004 3 rd edition Clause/Subclause	IEC 60068-2-58:201X 4 th edition Clause/Subclause	Notes
8	—	—
8.1	—	The prescriptions concerning lead-free solder alloys are allocated with the separate tests Td ₁ , Td ₂ , or Td ₃ , see below.
8.1.1	6.5.3.5 7.5.3.5	If applied to test Td ₁ If applied to test Td ₂
8.1.2	—	—
8.1.2.1	6.6.6	—
8.1.2.2	7.6.4.4	—
8.2	—	The prescriptions concerning lead containing solder alloys are allocated with the separate tests Td ₁ , Td ₂ , or Td ₃ , see below.
8.2.1	6.5.3.5 7.5.3.5 8.4.3	If applied to test Td ₁ If applied to test Td ₂ If applied to test Td ₃
8.2.2	6.6.6 7.6.4.4	If applied to test Td ₁ If applied to test Td ₂
8.2.3	6.6.6	—
8.2.4	7.6.4.4	—
9	9	—
10	10	—
Annex A	Annex A	—
Annex B	Annex B	—
Annex C	—	Information relevant to components for through-hole reflow soldering is available in IEC 61760-3.
Bibliography	Bibliography	—

Bibliography

IEC 60068-2-54, *Environmental testing – Part 2-54: Tests – Test Ta: Solderability testing of electronic components by the wetting balance method*

IEC 60068-2-69, *Environmental testing – Part 2-69: Tests – Test Te: Solderability testing of electronic components for surface mounting devices (SMD) by the wetting balance method*

IEC TR 60068-3-12, *Environmental testing – Part 3-12: Supporting documentation and guidance – Method to evaluate a possible lead-free solder reflow temperature profile*

IEC 60068-3-13, *Environmental testing – Part 3-13: Guidance on Test T: Soldering*³

IEC 60749-20, *Semiconductor devices – Mechanical and climatic test methods – Part 20: Resistance of plastic-encapsulated SMDs to the combined effect of moisture and soldering heat*

IEC 61760-3, *Surface mounting technology – Part 3: Standard method for the specification of components for through hole reflow (THR) soldering*

IEC 61760-4, *Surface mounting technology – Part 4: Standard method for classification, packaging, labelling and handling of moisture sensitive devices*⁴

J-STD 020D, *Moisture/Reflow Sensitivity Classification for Nonhermetic Solid State Surface Mount Devices*

<http://www.jedec.org/sites/default/files/docs/jstd020d-01.pdf>

J-STD 075, *Classification of Non-IC Electronic Components for Assembly Processes*

³ Under consideration.

⁴ To be published.

FINAL VERSION



**Environmental testing –
Part 2-58: Tests – Test Td: Test methods for solderability, resistance to
dissolution of metallization and to soldering heat of surface mounting devices
(SMD)**

CONTENTS

FOREWORD.....	5
1 Scope.....	7
2 Normative references	7
3 Terms and definitions	8
4 Grouping of soldering processes and related test severities	9
5 Test equipment.....	10
5.1 Solder bath	10
5.2 Reflow equipment	10
6 Test Td ₁ : Solderability of terminations.....	11
6.1 Object and general description of the test	11
6.2 Specimen preparation	11
6.3 Accelerated ageing	11
6.4 Initial measurements.....	11
6.5 Method 1: Solder bath.....	11
6.5.1 Solder bath.....	11
6.5.2 Solder and flux	11
6.5.3 Test procedure and conditions.....	12
6.6 Method 2: Reflow.....	14
6.6.1 Reflow equipment.....	14
6.6.2 Solder paste	14
6.6.3 Test substrates.....	14
6.6.4 Test procedure	14
6.6.5 Reflow temperature profile for Test Td ₁	15
6.6.6 Test conditions	16
7 Test Td ₂ : Resistance to soldering heat.....	16
7.1 Object and general description of the test	16
7.2 Specimen preparation	16
7.3 Preconditioning.....	16
7.4 Initial measurements.....	16
7.5 Method 1: Solder bath.....	17
7.5.1 Solder bath.....	17
7.5.2 Solder and flux	17
7.5.3 Test procedure and conditions.....	17
7.6 Method 2: Reflow.....	19
7.6.1 Reflow equipment.....	19
7.6.2 Solder paste	19
7.6.3 Test substrates.....	19
7.6.4 Test procedure and conditions.....	19
8 Test Td ₃ : Dewetting and resistance to dissolution of metallization.....	21
8.1 Object and general description of the test	21
8.2 Specimen preparation	21
8.3 Initial measurements.....	22
8.4 Method 1: Solder bath.....	22
8.4.1 Solder bath.....	22
8.4.2 Solder and flux	22

8.4.3	Test procedure and conditions	22
8.5	Method 2: Reflow	22
8.5.1	Reflow equipment	22
8.5.2	Specimen	22
8.5.3	Solder paste	22
8.5.4	Flux	22
8.5.5	Reflow profile	22
8.5.6	Placement of the specimen	23
8.5.7	Application of the reflow profile	23
8.5.8	Evaluation	23
9	Final measurements	23
9.1	Flux removal	23
9.2	Recovery conditions	23
9.3	Evaluation	23
9.3.1	Wetting	23
9.3.2	Dewetting	24
9.3.3	Resistance to soldering heat	25
9.3.4	Resistance to dissolution of metallization	25
10	Information to be given in the relevant specification	25
10.1	General	25
10.2	Solderability	25
10.3	Resistance to soldering heat, dewetting and resistance to dissolution of metallization	26
Annex A (normative)	Criteria for visual examination	27
A.1	Evaluation of wetting	27
A.1.1	General	27
A.1.2	Criteria for wetting	27
A.1.3	Additional criteria for wetting, method 2	28
A.2	Evaluation of dewetting, method 2	29
Annex B (informative)	Guidance	30
B.1	General	30
B.2	Limitations	30
B.3	Choice of severity	30
B.3.1	Test Td ₁ : Solderability by solder bath method	30
B.3.2	Test Td ₂ : Resistance to soldering heat – Solder bath method	31
B.3.3	Test Td ₂ : Resistance to soldering heat –Reflow method	31
B.3.4	Immersion attitude	32
B.3.5	Test Td ₃ : Dewetting and resistance to dissolution of metallization for 30 s at 260 °C	32
Annex C (normative)	Application of the test methods to through hole reflow soldering components (THR)	33
C.1	Solderability	33
C.2	Resistance to soldering heat	33
C.3	Dewetting	33
C.4	Criteria for evaluation	33
Annex X (informative)	Cross reference for references to the prior revision of this specification	34
Bibliography	36

Figure 1 – Examples of immersion attitudes.....	13
Figure 2 – Reflow temperature profile for solderability	15
Figure 3 – Examples of immersion attitude.....	18
Figure 4 – Reflow temperature profile for resistance to soldering heat	20
Figure 5 – Example for placement of a specimen to a test substrate	23
Figure 6 – Identification of areas on metallic termination.....	24
Figure A.1 – Evaluation of wetting.....	28
Figure A.2 – Evaluation of dewetting.....	29
Table 1 – Grouping of soldering processes and typical test severities – Overview.....	10
Table 2 – Solder alloy and flux for test Td ₁	12
Table 3 – Solderability – Test conditions and severity, solder bath method	14
Table 4 – Solder paste specification	14
Table 5 – Solderability – Test conditions – Method 2: Reflow	16
Table 6 – Resistance to soldering heat – Test conditions and severity, solder bath method	19
Table 7 – Resistance to soldering heat – Test conditions and severity, reflow method	21
Table 8 – Dewetting and resistance to dissolution of metallization – Test conditions and severity, solder bath method	22
Table B.1 – Test conditions.....	31
Table C.1 – Test conditions for solderability test.....	33

INTERNATIONAL ELECTROTECHNICAL COMMISSION

ENVIRONMENTAL TESTING –

Part 2-58: Tests – Test Td: Test methods for solderability, resistance to dissolution of metallization and to soldering heat of surface mounting devices (SMD)

FOREWORD

- 1) The International Electrotechnical Commission (IEC) is a worldwide organization for standardization comprising all national electrotechnical committees (IEC National Committees). The object of IEC is to promote international co-operation on all questions concerning standardization in the electrical and electronic fields. To this end and in addition to other activities, IEC publishes International Standards, Technical Specifications, Technical Reports, Publicly Available Specifications (PAS) and Guides (hereafter referred to as “IEC Publication(s)”). Their preparation is entrusted to technical committees; any IEC National Committee interested in the subject dealt with may participate in this preparatory work. International, governmental and non-governmental organizations liaising with the IEC also participate in this preparation. IEC collaborates closely with the International Organization for Standardization (ISO) in accordance with conditions determined by agreement between the two organizations.
- 2) The formal decisions or agreements of IEC on technical matters express, as nearly as possible, an international consensus of opinion on the relevant subjects since each technical committee has representation from all interested IEC National Committees.
- 3) IEC Publications have the form of recommendations for international use and are accepted by IEC National Committees in that sense. While all reasonable efforts are made to ensure that the technical content of IEC Publications is accurate, IEC cannot be held responsible for the way in which they are used or for any misinterpretation by any end user.
- 4) In order to promote international uniformity, IEC National Committees undertake to apply IEC Publications transparently to the maximum extent possible in their national and regional publications. Any divergence between any IEC Publication and the corresponding national or regional publication shall be clearly indicated in the latter.
- 5) IEC itself does not provide any attestation of conformity. Independent certification bodies provide conformity assessment services and, in some areas, access to IEC marks of conformity. IEC is not responsible for any services carried out by independent certification bodies.
- 6) All users should ensure that they have the latest edition of this publication.
- 7) No liability shall attach to IEC or its directors, employees, servants or agents including individual experts and members of its technical committees and IEC National Committees for any personal injury, property damage or other damage of any nature whatsoever, whether direct or indirect, or for costs (including legal fees) and expenses arising out of the publication, use of, or reliance upon, this IEC Publication or any other IEC Publications.
- 8) Attention is drawn to the Normative references cited in this publication. Use of the referenced publications is indispensable for the correct application of this publication.
- 9) Attention is drawn to the possibility that some of the elements of this IEC Publication may be the subject of patent rights. IEC shall not be held responsible for identifying any or all such patent rights.

DISCLAIMER

This Consolidated version is not an official IEC Standard and has been prepared for user convenience. Only the current versions of the standard and its amendment(s) are to be considered the official documents.

This Consolidated version of IEC 60068-2-58 bears the edition number 4.1. It consists of the fourth edition (2015-03) [documents 91/1222/FDIS and 91/1250/RVD] and its amendment 1 (2017-07) [documents 91/1445/FDIS and 91/1451/RVD]. The technical content is identical to the base edition and its amendment.

This Final version does not show where the technical content is modified by amendment 1. A separate Redline version with all changes highlighted is available in this publication.

International Standard IEC 60068-2-58 has been prepared by IEC technical committee 91: Electronics assembly technology.

This fourth edition constitutes a technical revision.

This edition includes the following significant technical changes with respect to the previous edition:

- the addition of Sn-Bi low temperature solder alloy;
- the addition of several reflow test conditions in Table 7 – Resistance to soldering heat – Test conditions and severity, reflow method;
- introduction of reflow test method for Test Td₃: Dewetting and resistance to dissolution of metallization;
- implementation of guidance for the choice of a test severity in Clause B.3.

This publication has been drafted in accordance with the ISO/IEC Directives, Part 2.

A list of all parts in the IEC 60068, published under the general title *Environmental testing*, can be found on the IEC website.

The committee has decided that the contents of the base publication and its amendment will remain unchanged until the stability date indicated on the IEC web site under "<http://webstore.iec.ch>" in the data related to the specific publication. At this date, the publication will be

- reconfirmed,
- withdrawn,
- replaced by a revised edition, or
- amended.

IMPORTANT – The 'colour inside' logo on the cover page of this publication indicates that it contains colours which are considered to be useful for the correct understanding of its contents. Users should therefore print this document using a colour printer.

ENVIRONMENTAL TESTING –

Part 2-58: Tests – Test Td: Test methods for solderability, resistance to dissolution of metallization and to soldering heat of surface mounting devices (SMD)

1 Scope

This part of IEC 60068 outlines test Td, applicable to surface mounting devices (SMD).

This document provides procedures for determining the solderability, resistance to dissolution of metallization and resistance to soldering heat of devices in applications using solder alloys, which are eutectic or near eutectic tin lead (Pb), or lead-free alloys.

The procedures use either a solder bath or reflow method and are applicable only to specimens or products designed to withstand short term immersion in molten solder or limited exposure to reflow systems.

The solder bath method is applicable to SMDs designed for flow soldering and SMDs designed for reflow soldering when the solder bath (dipping) method is appropriate.

The reflow method is applicable to the SMD designed for reflow soldering, to determine the suitability of SMDs for reflow soldering and when the solder bath (dipping) method is not appropriate.

The objective of this standard is to ensure solderability of component lead or termination. In addition, test methods are provided to ensure that the component body can resist against the heat load to which it is exposed during soldering.

This standard covers tests Td₁, Td₂ and Td₃ as listed below:

Number of Td	Test	Method
Td ₁	Solderability of terminations	Method 1: Solder bath Method 2: Reflow
Td ₂	Resistance to soldering heat	Method 1: Solder bath Method 2: Reflow
Td ₃	Dewetting and resistance to dissolution of metallization	Method 1: Solder bath Method 2: Reflow

NOTE 1 For specific components other test methods may exist.

NOTE 2 Test Td does not apply to printed wiring board (PWB), see IEC 61189-3.

NOTE 3 Specific through-hole devices (where the device supplier has specifically documented support for reflow soldering) are also included in this standard.

2 Normative references

The following documents, in whole or in part, are normatively referenced in this document and are indispensable for its application. For dated references, only the edition cited applies. For undated references, the latest edition of the referenced document (including any amendments) applies.

IEC 60068-1, *Environmental testing – Part 1: General and guidance*

IEC 60068-2-20:2008, *Environmental testing – Part 2-20: Tests – Test T: Test methods for solderability and resistance to soldering heat of devices with leads*

IEC 60194, *Printed board design, manufacture and assembly – Terms and definitions*

IEC 61190-1-1, *Attachment materials for electronic assemblies – Part 1-1: Requirements for soldering fluxes for high-quality interconnections in electronics assembly*

IEC 61190-1-2:2014, *Attachment materials for electronic assembly – Part 1-2: Requirements for solder pastes for high-quality interconnections in electronics assembly*

IEC 61190-1-3:2007, *Attachment materials for electronic assembly – Part 1-3: Requirements for electronic grade solder alloys and fluxed and non-fluxed solid solders for electronic soldering applications*

IEC 61190-1-3:2007/AMD1:2010

IEC 61191-2, *Printed board assemblies – Part 2: Sectional specification – Requirements for surface mount soldered assemblies*

IEC 61249-2-22, *Materials for printed boards and other interconnecting structures – Part 2-22: Reinforced base materials clad and unclad – Modified non-halogenated epoxide woven E-glass laminated sheets of defined flammability (vertical burning test), copper-clad*

IEC 61249-2-35, *Materials for printed boards and other interconnecting structures – Part 2-35: Reinforced base materials, clad and unclad – Modified epoxide woven E-glass laminate sheets of defined flammability (vertical burning test), copper-clad for lead-free assembly*

IEC 61760-1, *Surface mounting technology – Part 1: Standard method for the specification of surface mounting components (SMDs)*

ISO 9454-2:1998, *Soft soldering fluxes – Classification and requirements – Part 2: Performance requirements*

3 Terms and definitions

For the purposes of this document, the terms and definitions given in IEC 60068-1, IEC 60068-2-20, IEC 60194, and the following apply.

3.1

solderability

ability of the termination or electrode of the SMD to be wetted by solder at the temperature of the termination or electrode, which is assumed to be the lowest temperature in the soldering process, within the applicable temperature range of the solder alloy

3.2

resistance to soldering heat

ability of the component to withstand the highest temperature stress in terms of temperature gradient, peak temperature and duration of the soldering process, within the applicable temperature range of the solder alloy

3.3

flow soldering

wave, drag or dip soldering process where the product is brought into contact with molten solder in order to attach electronic components to the interconnecting surface

3.4

reflow soldering

joining of surfaces that have been tinned and/or have solder between them, placing them together, heating them until the solder flows, and allowing the surface and the solder to cool in the joined position

3.5

wetting

formation of an adherent coating of solder on a surface indicated by a small contact angle

3.6

dewetting

retraction of molten solder on a solid area that it has initially wetted

Note 1 to entry: In some cases an extremely thin film of solder may remain. As the solder retracts the contact angle increases.

3.7

non-wetting

inability to form an adherent coating of solder on a surface indicated by a contact angle greater than 90°

3.8

dissolution of metallization

process of dissolving metal, usually by introduction of chemicals

3.9

pinhole

small hole that penetrates from the surface of a solder to base material

4 Grouping of soldering processes and related test severities

The melting temperatures of lead-free solder alloys selected for industrial processes are significantly different from those for Sn-Pb solder alloy. Moreover, the melting temperatures of lead-free solder alloys are different from each other but can be clustered in groups.

The following groups of soldering processes as indicated in Table 1, are given as a guideline to select the severities for the wetting and resistance tests against the specified soldering heat:

Table 1 – Grouping of soldering processes and typical test severities – Overview

Process temperature group ^a		1 Low	2 Medium	3 Medium-high	4 High
Typical solder alloy group		Sn-Bi	Sn-Pb	Sn-Ag-Cu	Sn-Cu
Typical process temperature	Flow	–	235 °C to 250 °C	250 °C to 260 °C	250 °C to 260 °C ^c
	Reflow	170 °C to 210 °C	210 °C to 240 °C	235 °C to 250 °C	–
Test method	Test property	Temperature / Duration			
Solder bath	Solderability (6.5)	175 °C / 3 s	235 °C / 2 s	245 °C / 3 s	250 °C / 3 s
	Resistance to soldering heat (7.5)	230 °C / 10 s	260 °C / 5 s	260 °C / 5 s	260 °C / 10 s
			260 °C / 10 s	260 °C / 10 s	
	Dewetting (8.2)	–	260 °C / 5 s	–	–
260 °C / 10 s			–	–	
Resistance to dissolution of metallization (8.2)	–	260 °C / 30 s			
Reflow	Solderability ^b (6.6)	170 °C / 10 s	215 °C / 10 s	235 °C / 10 s	–
	Resistance to soldering heat (7.6)	–	235 °C / 20 s	230 °C / 30 s	–
				245 °C / 30 s	
	Dewetting (8.2)	–	235 °C / 20 s	250 °C / 30 s	–
260 °C / 30 s					
^a Refer to the appropriate subclauses for the detailed test conditions. ^b Measured at the solder joint. ^c 255 °C to 265 °C may be an applicable soldering temperature range for boards with high thermal demand.					

The following statements shall be applied in Table 1;

- Flow soldering applies to both wave soldering and dip soldering.
- Typical process temperatures for flow soldering are identical to the solder temperature. Typical process temperatures for reflow soldering are the terminal and top surface temperature of the SMDs.
- The basic solder alloys listed in Table 1 present tin-lead solder and compositions that are currently preferred for lead-free soldering processes. However, other solder alloys when matching with the specified group should not be excluded.

5 Test equipment

5.1 Solder bath

As given in IEC 60068-2-20:2008, 5.2.1, the solder bath shall be not less than 40 mm in depth and not less than 300 ml in volume.

In case of high thermal capacity components, the volume of the solder bath shall be given by the relevant specification.

The material of the solder bath container shall be resistant to the liquid solder alloy.

5.2 Reflow equipment

As long as the test conditions are fulfilled, any reflow equipment may be used. The following two methods are preferred:

- g) forced gas convection;
- h) vapour phase.

NOTE 1 Forced gas convection is preferred, including infrared assistance.

NOTE 2 In case of vapour phase soldering, a specific vapour creating liquid is necessary for each test temperature.

6 Test Td₁: Solderability of terminations

6.1 Object and general description of the test

Test Td₁ provides two different test methods to determine the solderability of the metallized end cap terminations and metallic terminations which meets the applicable solder joint requirements of IEC 61191-2 using each of the soldering methods specified in IEC 61760-1.

- Method 1: Solder bath
- Method 2: Reflow

The test method to be used shall be prescribed in the relevant specification.

NOTE 1 The solder bath method is the one that simulates most closely the soldering procedures of flow soldering and similar soldering processes where the heat is applied directly through conduction from a molten solder.

NOTE 2 The reflow method is the one that simulates most closely the soldering procedures of reflow soldering processes, like forced gas convection or vapour phase, where the heat is applied by gas convection or vapour condensation.

6.2 Specimen preparation

The surface to be tested shall be in the "as received" condition and needs to be shielded from any kind of contamination, e.g. it shall not be subsequently touched by fingers.

The specimens shall not be cleaned prior to the application of a solderability test. If required by the relevant specification, the specimens may be degreased by immersion in a neutral organic solvent at room temperature.

6.3 Accelerated ageing

When accelerated ageing is prescribed by the relevant specification, one of the methods of IEC 60068-2-20:2008, 4.1.4 shall be used.

6.4 Initial measurements

The specimens shall be visually examined and, if required by the relevant specification, electrically and mechanically checked.

6.5 Method 1: Solder bath

6.5.1 Solder bath

See 5.1.

6.5.2 Solder and flux

The solder alloy shall be selected from Table 2, unless otherwise prescribed by the relevant specification.

Table 2 – Solder alloy and flux for test Td₁

Process temperature group	Solder alloy ^a and flux
1	Sn42Bi58 ^b
2	Sn60Pb40A or Sn63Pb37A
3	Sn96,5Ag3Cu,5
4	Sn99,3Cu,7
^a Solder alloy designations and tolerance of composition according to IEC 61190-1-3:2007 and Amendment 1:2010, Annex B. ^b Activated with 0,2 % chloride.	

The flux shall consist of 25 % mass fraction of colophony in 75 % mass fraction of 2-propanol (isopropanol) or ethyl alcohol (as specified in IEC 60068-2-20:2008, Annex B). Preferably the flux activity should conform with the “low (<0,01)” level L0, corresponding to a halide mass fraction of <0,01 % (Cl, Br, F) (see IEC 61190-1-1).

If non-activated flux is inappropriate, the relevant specification may prescribe the use of the above flux with the addition of diethylammonium chloride (analytical reagent grade) of a mass fraction of 0,2 % or 0,5 % chloride (expressed as free chlorine based on the colophony content), see Table 2.

6.5.3 Test procedure and conditions

6.5.3.1 Specimen

A specimen shall not be used for more than one test.

6.5.3.2 Clamping

The specimen shall be placed in a stainless steel clip as shown in Figure 1, where the cross sectional area of that clip shall not exceed the smallest cross sectional area of the specimen, unless otherwise prescribed by the relevant specification. No part of the clip jaws shall make contact with the areas to be examined. The specimen shall remain in the clip while being fluxed and dipped in the solder.

NOTE A clip with a thermal capacity of its dipped part significantly exceeding the thermal capacity of the specimen may lead to a decrease of the local bath temperature next to the specimen and thereby to an increase of the effective severity of this test.

6.5.3.3 Fluxing

The specimen shall be completely immersed in flux and withdrawn slowly, unless otherwise prescribed by the relevant specification. Any excess flux shall be removed by contact with absorbent paper.

6.5.3.4 Solder immersion

If the preheating is prescribed by the relevant specification, the specified duration and temperature shall be applied immediately prior to the immersion of the specimen in the solder bath.

The oxide film on the solder bath shall be skimmed off immediately before immersion.

The immersion and withdrawal speed shall be in the range of 20 mm/s to 25 mm/s.

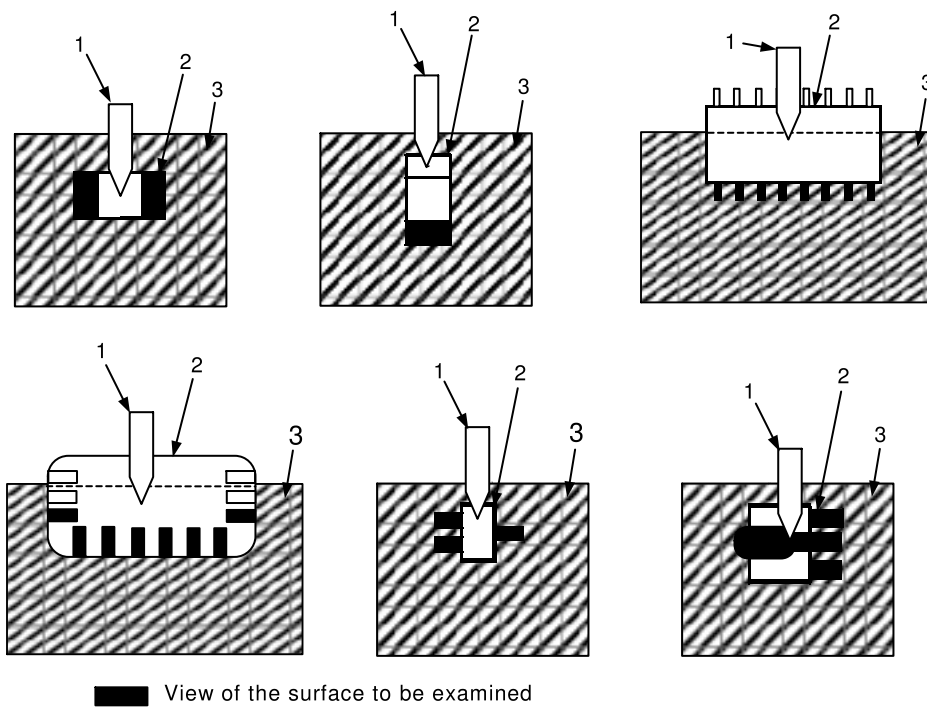

IEC

Key

- 1 Clip
- 2 Specimen
- 3 Solder

The immersion method may not be applicable for high thermal capacity components. The method to be applied for such components shall be given in the relevant specification.

Figure 1 – Examples of immersion attitudes

Two attitudes of immersion are standardized:

Attitude A: For most specimens, the areas to be examined shall be immersed not less than 2 mm below the solder meniscus (but not to a greater depth than necessary; see Figure 1) with the seating plane vertical.

Attitude B: For certain specimens (see B.3.4), the specimen may be floated on the solder.

Attitude A shall be applied, if the relevant specification does not prescribe an attitude to be used.

6.5.3.5 Test conditions

The duration and temperature of immersion shall be selected from Table 3, unless otherwise prescribed by the relevant specification.

Table 3 – Solderability – Test conditions and severity, solder bath method

Group	Alloy name	Test conditions and severity ^a	
		Temperature	Time
1	Sn42Bi58 (activated flux, 0,2 % chloride)	(175 ± 3) °C	(3 ± 0,5) s
2	Sn60Pb40A or Sn63Pb37A	(215 ± 3) °C	(3 ± 0,2) s
		(235 ± 3) °C	(2 ± 0,2) s
3	Sn96,5Ag3Cu,5	(245 ± 3) °C	(3 ± 0,3) s
4	Sn99,3Cu,7	(250 ± 3) °C	(3 ± 0,3) s

^a For components having a high thermal capacity the relevant specification may prescribe an extension of the immersion time up to (10 ± 1) s.

6.6 Method 2: Reflow

6.6.1 Reflow equipment

See 5.2.

6.6.2 Solder paste

Solder paste shall be as in Table 4, unless otherwise prescribed by the relevant specification.

Table 4 – Solder paste specification

Group	Alloy name ^a	Flux classification ^b		Powder size type ^c	Nominal metal content, mass fraction %
		IEC	ISO		
1	Sn42Bi58	ROL0	1.1.1	3	90
2	Sn60Pb40A or Sn63Pb37A	ROL0	1.1.1	3	90
3	Sn96,5Ag3Cu,5	ROL0	1.1.1	3	88
4	–	–	–	–	–

^a Solder alloy designations and tolerance of composition according to IEC 61190-1-3:2007 and Amendment 1:2010, Annex B.
^b Refer to IEC 61190-1-1 or ISO 9454-2 for details.
^c Refer to IEC 61190-1-2:2014, Table 2. Any other powder size should be prescribed in the relevant specification.

6.6.3 Test substrates

The test substrate shall consist of an unmetallized and non-wettable (no tracks or lands) piece of ceramic (alumina 90 % to 98 %) or epoxide woven E-glass laminated circuit board as defined, for example, in IEC 61249-2-22 or IEC 61249-2-35.

For the solderability test, the test substrate should not have solder lands, as a visual examination of the bottom side of the termination/electrode is required. See Annex A.

Dimensional details and the number of sample(s) to be tested shall be given in the relevant specification.

6.6.4 Test procedure

6.6.4.1 Specimens

A specimen shall not be used for more than one test.

6.6.4.2 Application of solder paste

The solder paste shall be applied to the test substrate by screen or stencil printing, dispensing or pin transfer.

The area (size) to be printed, and thus the amount of solder paste deposit, shall be specified in the relevant specification. When solder paste is applied by dispensing or pin transfer, the volume shall be adjusted so that a comparable solder volume can be achieved.

NOTE The thickness of the solder deposit is in the range from 60 μm to 250 μm .

6.6.4.3 Placement of specimens

After printing, the terminations of the specimen shall be placed on the solder paste. The placement procedure (for example depth of penetration) shall be prescribed in the relevant specification.

6.6.5 Reflow temperature profile for Test Td_1

As a minimum, the following parameters shown in Figure 2 shall be specified for the reflow temperature profile.

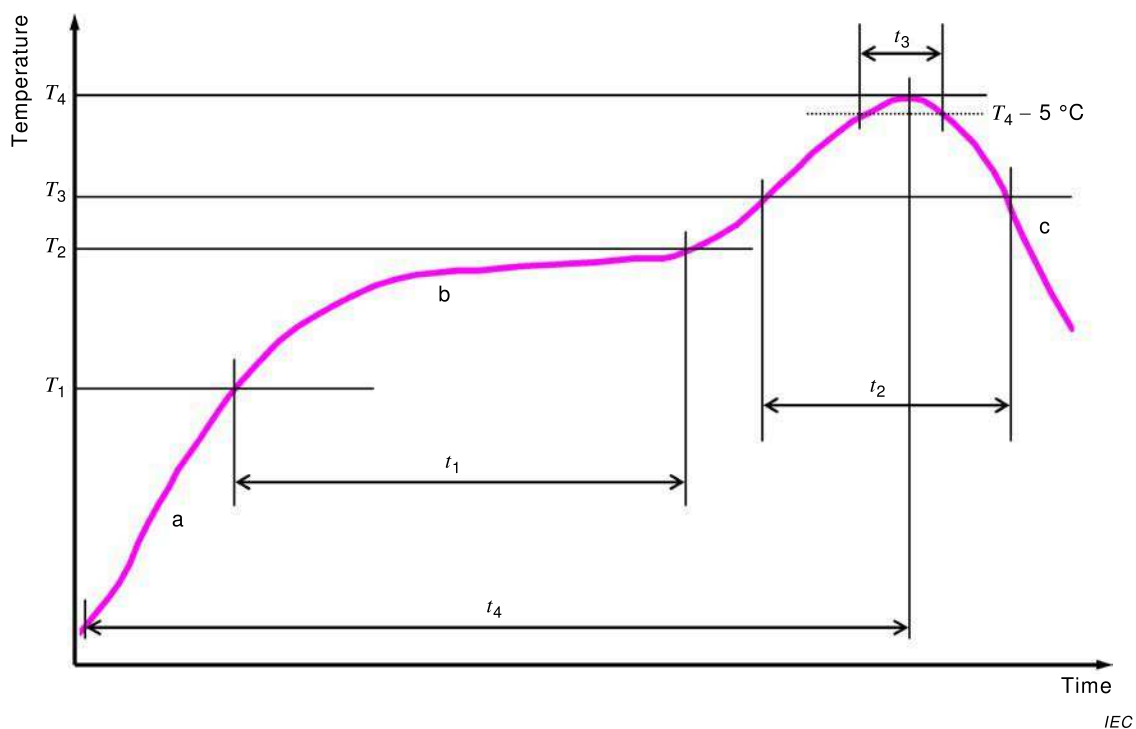

Key

- T_1 Minimum preheating temperature
- T_2 Maximum preheating temperature
- T_3 Liquidus temperature
- T_4 Peak temperature
- t_1 Preheating duration
- t_2 Time above liquidus temperature
- t_3 Time above $(T_4 - 5\text{ °C})$
- t_4 Time to T_4
- a The temperature gradient of the increasing slope shall not exceed 3 K/s.
- b Preheat area.
- c The temperature gradient of the decreasing slope shall not exceed 6 K/s.

Figure 2 – Reflow temperature profile for solderability

The temperature shall be measured at the specimen termination, unless otherwise prescribed by the relevant specification.

6.6.6 Test conditions

The parameters for the temperature profile shall be selected from Table 5, unless otherwise prescribed by the relevant specification.

Table 5 – Solderability – Test conditions – Method 2: Reflow

Group	Solder alloy	T_1 °C	T_2 °C	t_1 s	T_3 °C	t_2 s	T_4^a °C	t_3^b s
1	Sn42Bi58	100 ± 5	130 ± 5	60 to 120	138	40 ± 5	170	10
2	Sn63Pb37A Sn60Pb40A	100	150	60 to 120	183	40 ± 5	215	10
3	Sn96,5Ag3Cu,5	150	180	60 to 120	217	40 ± 5	235	10
4	Not applicable							
^a Peak temperature (T_4) is defined as minimum for acceptance testing and maximum for qualification testing. ^b Time above ($T_4 - 5$ °C) is defined as minimum for acceptance testing and maximum for qualification testing.								

7 Test Td_2 : Resistance to soldering heat

7.1 Object and general description of the test

Test Td_2 provides two different test methods to evaluate the soldering heat resistance of SMD.

- Method 1: Solder bath (Not applicable to the component designed for reflow soldering only)
- Method 2: Reflow

The test method to be used shall be indicated in the relevant specification.

NOTE 1 The solder bath method is the one that simulates most closely the soldering procedures of flow soldering and similar soldering process where the heat is applied directly through conduction from a molten solder.

NOTE 2 The reflow method is the one that simulates most closely the soldering procedures of reflow soldering processes, like forced gas convection or vapour phase, where the heat is applied by gas convection or vapour condensation.

NOTE 3 The relevant specification may specify a reflow soldering simulation test without application of solder paste (e.g. see IEC 60749-20 for semiconductor devices).

7.2 Specimen preparation

The surface to be tested shall be in the "as received" condition and needs to be shielded from any kind of contamination, e.g. shall not be subsequently touched by fingers.

If required by the relevant specification, the specimen may be degreased by immersion in a neutral organic solvent at room temperature.

7.3 Preconditioning

In case of moisture sensitive devices (MSD) pre-drying may be needed.

NOTE 1 When moisture sensitive devices (MSD) are tested, moisture soak can be considered to determine the influence of absorbed moisture to the resistance against soldering heat under worst case conditions.

NOTE 2 Examples for suitable soak procedures may be found in IEC 60749-20, or IEC 61760-4.

7.4 Initial measurements

The specimens shall be visually examined and, if required by the relevant specification, electrically and mechanically checked.

7.5 Method 1: Solder bath

7.5.1 Solder bath

See 5.1.

7.5.2 Solder and flux

For the resistance to the soldering heat test, any alloys may be used, provided they are completely liquid at the required temperature.

The flux shall consist of a mass fraction of 25 % of colophony in a mass fraction of 75 % of 2-propanol (isopropanol) or ethanol (ethyl alcohol), as specified in IEC 60068-2-20:2008, Annex B, activated by the addition of diethylammonium chloride (analytical reagent grade), of a mass fraction of 0,5 % chloride (expressed as free chlorine based on the colophony content).

Information concerning the used flux type shall be given in the product detail specification.

7.5.3 Test procedure and conditions

7.5.3.1 Specimens

A specimen shall not be used for more than one test.

7.5.3.2 Clamping

The specimen shall be placed in a stainless steel clip as shown in Figure 1, where the cross sectional area of that clip shall not exceed the smallest cross sectional area of the specimen, unless otherwise prescribed by the relevant specification. No part of the clip jaws shall make contact with the areas to be examined. The specimen shall remain in the clip while being fluxed and dipped in the solder.

NOTE A clip with a thermal capacity of its dipped part significantly exceeding the thermal capacity of the specimen may lead to a decrease of the local bath temperature next to the specimen and thereby to a decrease of the effective severity of this test.

7.5.3.3 Fluxing

The specimen shall be completely immersed in flux and withdrawn slowly, unless otherwise prescribed by the relevant specification. Any excess flux shall be removed by contact with absorbent paper.

7.5.3.4 Solder immersion

If preheating is prescribed by the relevant specification, the specified duration and temperature shall be applied immediately prior to the immersion of the specimen in the solder bath.

The oxide film on the solder bath shall be skimmed off immediately before immersion.

The immersion and withdrawal speed shall be in the range of 20 mm/s to 25 mm/s.

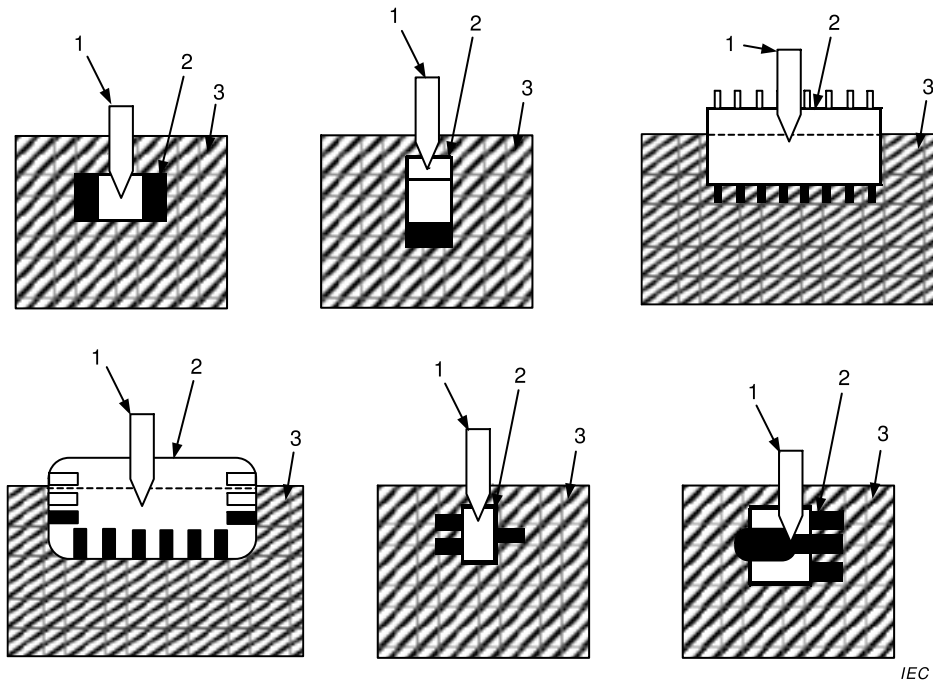

Key

- 1 Clip
- 2 Specimen
- 3 Solder

The methods shown may not be applicable to high thermal capacity components. Immersion method for high thermal capacity components shall be given in the relevant specification.

Figure 3 – Examples of immersion attitude

Two attitudes of immersion are standardized:

Attitude A: For most specimens, the areas to be examined shall be immersed not less than 2 mm below the solder meniscus (but not to a greater depth than necessary; see Figure 3) with the seating plane vertical.

Attitude B: For certain specimens (see B.3.4), the specimen may be floated on the solder.

If the relevant specification does not mention the attitude, attitude A shall be adopted.

7.5.3.5 Test conditions – Method 1: Solder bath

The duration and temperature of immersion shall be selected from Table 6, unless otherwise prescribed by the relevant specification.

**Table 6 – Resistance to soldering heat –
 Test conditions and severity, solder bath method**

Group	Alloy composition ^a	Test conditions and severity	
1	Sn42Bi58	(230 ± 3) °C	(10 ± 1) s
2	Sn60Pb40A or Sn63Pb37A	(260 ± 5) °C	(5 ± 1) s
			(10 ± 1) s
3	Sn96,5Ag3Cu,5	(260 ± 5) °C ^b	(5 ± 1) s
			(10 ± 1) s
4	Sn99,3Cu,7	(260 ± 5) °C ^b	(10 ± 1) s

^a Alloy compositions given here are for information only and do not state any prescription for specific alloys to be used in this test, see 7.5.2.

^b Certain soldering methods may require the higher severity of (270 ± 3) °C for (5 ± 0,5) s or the more severe condition of (10 ± 1) s. Such conditions should be provided by the detail specification or agreed between the trading partners.

7.6 Method 2: Reflow

7.6.1 Reflow equipment

See 5.2.

7.6.2 Solder paste

Solder paste is normally not required for the resistance to soldering heat test.

7.6.3 Test substrates

If required, the test substrate shall consist of an unmetallized and non-wettable (no tracks or lands) piece of ceramic (alumina 90 % to 98 %) or epoxide woven E-glass laminated circuit board as defined, for example, in IEC 61249-2-22 or IEC 61249-2-35.

For the resistance to soldering heat test, the test substrate should not have solder lands, as a visual examination of the bottom side of the component is required. See Annex A.

Dimensional details and the number of sample(s) to be tested shall be given in the relevant specification.

This test does not cover additional stresses to the test specimen by circuit boards. The mounting to test substrates before testing shall be described by the relevant specification.

7.6.4 Test procedure and conditions

7.6.4.1 Specimens

A specimen shall not be used for more than one test. The specimen may be tested with or without solder paste, as required by the relevant specification.

7.6.4.2 Application of solder paste

If required, the solder paste shall be applied to the test substrate by screen or stencil printing, dispensing or pin transfer as specified in the relevant specification. In this case the area (size) to be printed and the thickness of the solder paste deposit shall be specified in the relevant specification. When solder paste is applied by dispensing or pin transfer, the volume shall be adjusted so that a comparable solder volume can be achieved.

7.6.4.3 Placement of specimens

As applicable, after printing, the terminations of the specimen shall be placed on the solder paste or the substrate. The placement procedure (for example depth of penetration) shall be prescribed in the relevant specification.

7.6.4.4 Reflow temperature profile

As a minimum, the following parameters shown in Figure 4 shall be specified for the reflow temperature profile.

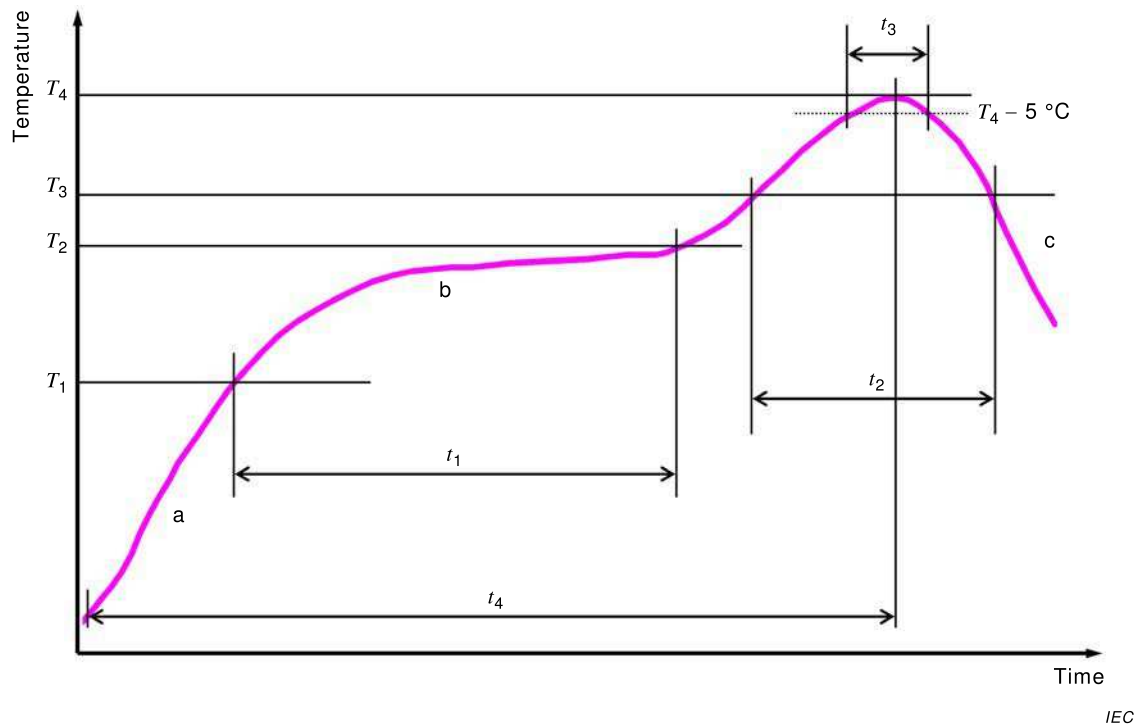

T_1 Minimum preheating temperature

T_2 Maximum preheating temperature

T_3 Liquidus temperature

T_4 Peak temperature

t_1 Preheating duration

t_2 Time above liquidus temperature

t_3 Time above $(T_4 - 5 \text{ °C})$

t_4 Time to T_4

a The temperature gradient of the increasing slope shall not exceed 3 K/s.

b Preheat area

c The temperature gradient of the decreasing slope shall not exceed 6 K/s.

Figure 4 – Reflow temperature profile for resistance to soldering heat

The temperature shall be measured at the specimen's top body surface (peak package body temperature), unless otherwise prescribed by the relevant specification.

The reflow temperature profile for resistance to soldering heat test shall be as specified in Table 7, unless otherwise prescribed by the relevant specification.

NOTE A forced gas convection oven is recommended to ensure reproducibility of the reflow temperature profile.

The number of test cycles shall be a minimum of one and a maximum of three, and shall be specified in the relevant specification, unless otherwise prescribed by the relevant specification. The recovery period between two successive cycles shall be the time it takes until the temperature of the specimen drops below 50 °C.

**Table 7 – Resistance to soldering heat –
 Test conditions and severity, reflow method**

Group	Alloy name	T_1 °C	T_2 °C	t_1^f s	T_3 °C	t_2^g s	T_4^a °C	$t_3^{b,a}$ s	t_4 s
1	Sn42Bi58				138				
2	Sn63Pb37A Sn60Pb40A	100	150	60 to 120	183	30 to 60 ^e 60 to 150	215 235	10 ± 1 20 ± 1 30 ± 1 40 ± 1	360 max
3	Sn96,5Ag3Cu,5	150	200		217		220 to 235 ^c	20 to 40 ^c	480 max
							230 to 260 ^e	5 max ^e 10 max ^e	
					245 250 260	20 ± 1 30 ± 1 ^d			
<p>^a The combination of temperature and time is determined by the thermal mass of the component and shall be given by the relevant specification. Further information how to determine applicable test conditions, see IEC TR 60068-3-12. Peak temperature (T_4) measured at the specimen's top body surface is defined as maximum for acceptance testing and minimum for qualification testing.</p> <p>^b Tolerance for time above ($T_4 - 5$ °C) is defined maximum as for acceptance testing and minimum for qualification testing.</p> <p>^c Components with high thermal mass may require this severity; details shall be provided by the relevant specification.</p> <p>^d A more severe t_3 of (40 ± 1) s is also in use for certain applications with high package density / high thermal mass PCB.</p> <p>^e Applicable for high thermal sensitivity.</p> <p>^f Depending on the thermal mass of the components, the time t_1 may be extended.</p> <p>^g The time t_2 depends on the thermal mass of the components.</p>									

8 Test Td₃: Dewetting and resistance to dissolution of metallization

8.1 Object and general description of the test

Test Td₃ provides a test method to evaluate the loss of wetting ability of a terminal surface during soldering (dewetting), or the loss of solderable area of a terminal surface by dissolution of metallization.

- Method 1: Solder bath
- Method 2: Reflow

The test method to be used shall be indicated in the relevant specification.

NOTE Reflow test method to determine the dewetting

8.2 Specimen preparation

The surface to be tested shall be in the "as received" condition and needs to be shielded from any kind of contamination, e.g. shall not be subsequently touched by the fingers or otherwise contaminated.

If required by the relevant specification, the specimen may be degreased by immersion in a neutral organic solvent at room temperature.

In case of MSD pre-drying may need to be considered.

8.3 Initial measurements

The specimens shall be visually examined and, if required by the relevant specification, electrically and mechanically checked.

8.4 Method 1: Solder bath

8.4.1 Solder bath

See 5.1.

8.4.2 Solder and flux

See 7.5.2.

8.4.3 Test procedure and conditions

The duration and temperature of immersion shall be selected from Table 8, unless otherwise prescribed by the relevant specification.

If a total immersion time of 10 s is required because dewetting can occur slowly, this immersion shall be divided into two periods of 5 s each in order that any rapid dewetting is not masked by any subsequent re-wetting.

Guidance on the choice of severities, including those for lower grades of dissolution of metallization, is given in Clause B.3.

The speed of dewetting and dissolution of metallization depends on temperature, time and the combination of terminal surface material and solder alloy.

**Table 8 – Dewetting and resistance to dissolution of metallization –
Test conditions and severity, solder bath method**

Property tested	Severity		
	(260 ± 5) °C		
	(5 ± 0,5) s	(10 ± 1) s	(30 ± 1) s
Dewetting	X	X	
Resistance to dissolution of metallization			X
X" denotes 'applicable'.			

8.5 Method 2: Reflow

8.5.1 Reflow equipment

See 5.2.

8.5.2 Specimen

A specimen shall not be used for more than one test. The test applies only for specimens with a pin finish that will melt during the reflow process, this is not the case for, for example, NiPdAu pin finishes.

8.5.3 Solder paste

Solder paste is not required for this test.

8.5.4 Flux

Flux shall be used as described in Table 4, or as required in the relevant specification. It shall be applied by a brush on the termination of the tested component.

8.5.5 Reflow profile

Reflow profile as described in Figure 4 and Table 7 shall be applied, unless otherwise prescribed by the relevant specification.

8.5.6 Placement of the specimen

The specimens to be tested shall be fixed to a suitable substrate in a way, (e.g. with a high temperature double sided adhesive tape) that they will not move during the reflow test. The components shall be fixed upside down (on the tape), and the terminations shall show upwards, as demonstrated in Figure 5 and parallel to the carrier.

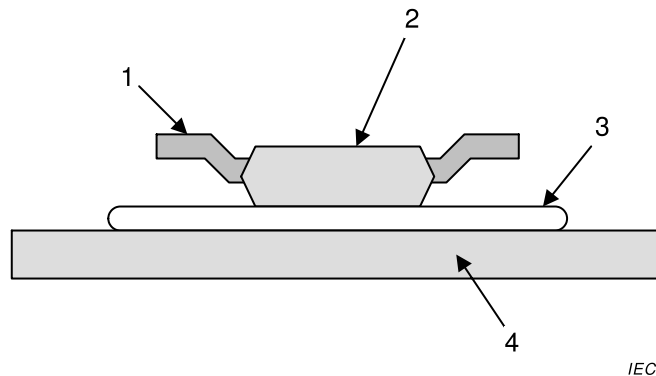

IEC

Key

- 1 Termination
- 2 Component (upside down)
- 3 High temperature double sided adhesive tape
- 4 Substrate

Figure 5 – Example for placement of a specimen to a test substrate

8.5.7 Application of the reflow profile

The selected reflow profile shall be applied once to the specimen on the carrier, in order to melt the termination finish.

8.5.8 Evaluation

Dewetting shall not exceed the criteria described in Clause A.2.

Note that this test does not directly assess the dewetting but assesses the possibility of the dewetting.

9 Final measurements

9.1 Flux removal

Within 60 min of the test and after the specimen has been allowed to cool to room temperature, the flux residues shall be removed with a suitable solvent. After cooling, the specimen shall be removed from the substrate for inspection. Details of the removal procedure shall be given in the relevant specification.

9.2 Recovery conditions

The recovery conditions shall be prescribed in the relevant specification.

9.3 Evaluation

9.3.1 Wetting

9.3.1.1 General

The wetting shall be assessed visually under adequate light with a binocular microscope of a magnification in the range of 10× to 25×, using the photographs of component terminations in Clause A.1 to assist with the evaluation. The areas to be examined shall be prescribed in the relevant specification.

9.3.1.2 Metallized end cap terminations (rectangular or circular configuration)

The dipped or reflowed surface shall be covered with solder coating with no more than small amounts of scattered imperfections, such as pinholes or non-wetted or dewetted areas. These imperfections shall not be concentrated in one area. Additionally, for solder alloy containing lead, solder coating shall be smooth and bright.

9.3.1.3 Metallic terminations shorter than 6 mm (dimension “d” in Figure 6)

The following criteria apply where the specimen is tested in the “as-received” condition or after accelerated ageing.

a) Areas that form the joint (area “a” in Figure 6):

- 1) the underside of the termination foot (area “d” in Figure 6) and the convex side of the lower bend;
- 2) the side faces of the foot.

The highest quality is required in these areas. The dipped or reflowed surface shall be covered with solder coating with no more than small amounts of scattered imperfections such as pinholes, non-wetted or dewetted areas. These imperfections shall not be concentrated in one area. For solder alloy containing lead, the solder coating shall be smooth and bright.

b) The upper side of the termination (area “b” in Figure 6).

After the dipping test, the dipped surface shall show visible evidence of being wettable, as indicated by the presence of fresh solder. A homogeneous coating is not necessary here.

c) Non-coated cut edges at the end of the termination and the termination above the lower bend (area “c” in Figure 6).

For these areas (“b”, “c” and “d”), no quality criterion of solder coating is given.

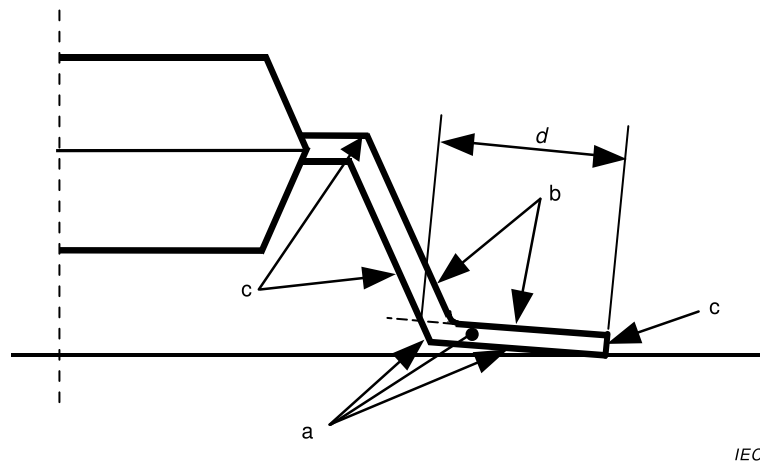

Figure 6 – Identification of areas on metallic termination

9.3.1.4 Other metallic terminations

The areas to be examined and criteria for evaluation shall be specified in the relevant specification.

9.3.2 Dewetting

If applicable, the criteria for wetting described in 9.3.1 shall also apply.

The dewetting shall be assessed visually under adequate light with a binocular microscope of magnification in a range of 10x to 100x.

9.3.3 Resistance to soldering heat

After testing for resistance to soldering heat, the specimen shall be electrically checked and visually examined in accordance with the relevant specification.

9.3.4 Resistance to dissolution of metallization

If applicable, the following criteria shall apply. If these criteria cannot be applied, they shall be prescribed in the relevant specification.

- a) Areas where metallization is lost during immersion shall not individually exceed 5 % of the total electrode area, and collectively shall not exceed 10 % of the total electrode area.
- b) The functional connection of the electrode to the interior of the specimen shall not be exposed.
- c) Where the metallization of the electrode extends over edges onto adjacent surfaces, loss of metallization on the edges shall not exceed 10 % of their total length.

10 Information to be given in the relevant specification

10.1 General

If this test is included in a specification, the following details shall be given insofar as they are applicable. Particular attention shall be given to items marked with an asterisk (*) as this information is mandatory.

10.2 Solderability

The following details shall be applied for solderability.

- a) Property to be tested *
- b) Applicable test method *
- c) Condition of preconditioning (if required) *
- d) For solder bath method
 - 1) Selected solder alloy *
 - 2) Flux type *
 - 3) Clamping, fluxing and solder immersion *
 - 4) Preheating *
 - 5) Attitude to be used
 - 6) Solder temperature and duration *
- e) For reflow method
 - 1) Solder paste *
 - 2) Dimensional details of test substrate *
 - 3) Thickness of solder paste *
 - 4) Amount of solder paste
 - 5) Placement procedure
 - 6) Temperature profile *
 - 7) Temperature measurement point *
- f) Removal procedure
- g) Cleaning method
- h) Recovery conditions
- i) Areas of the terminations to be examined *
- j) Final inspection requirements and acceptance criteria *

10.3 Resistance to soldering heat, dewetting and resistance to dissolution of metallization

The following details shall be applied for resistance to soldering heat, dewetting and resistance to dissolution of metallization.

- a) Property to be tested *
- b) Applicable test method *
- c) Condition of preconditioning (if required) *
- d) For solder bath method
 - 1) Selected solder alloy *
 - 2) Flux type *
 - 3) Clamping, fluxing and solder immersion *
 - 4) Preheating *
 - 5) Attitude to be used
 - 6) Solder temperature and duration *
 - 7) Number of test cycles if other than 1 cycle (for resistance to soldering heat) *
- e) For reflow method
 - 1) Solder paste (if required) *
 - 2) Dimensional details of test substrate (for resistance to soldering heat and if required) *
 - 3) Thickness of solder paste (if required) *
 - 4) Amount of solder paste (if required)
 - 5) Placement procedure (if required) *
 - 6) Temperature profile *
 - 7) Temperature measurement point *
 - 8) Number of test cycles for resistance to soldering heat *
- f) Removal procedure
- g) Cleaning method
- h) Recovery conditions
- i) Areas of the terminations to be examined *
- j) Final inspection requirements and acceptance criteria *

Annex A (normative)

Criteria for visual examination

A.1 Evaluation of wetting

A.1.1 General

In various specifications, a complete or nearly complete coating with solder is often defined by the so-called 95 % requirement. The application of this requirement is often difficult when assessing specimens with metallized terminations or with short metallic terminations, especially when different parts of the termination are distinguished. Nevertheless, the same approach is followed here.

A.1.2 Criteria for wetting

Acceptable when 95 % or more area to be evaluated covered by an ideal solder coating with a dewetting area is scattered and not concentrated in one area.

Figure A.1 comprises six examples illustrating the criteria for visual examination.

NOTE To help in the evaluation of wetting, the photographs in Figure A.1 have been reproduced on such a scale that the dimensions are reasonably comparable with the view obtained under a microscope, while ensuring that smaller details are still sufficiently clear.



Acceptable	Unacceptable
 <p style="text-align: right;"><i>IEC</i></p> <p>Acceptable: ideal coating both on the foot and on the sides; the visible rim is not dewetted because there is no contact angle; the flux residues between body and termination have not been removed.</p>	 <p style="text-align: right;"><i>IEC</i></p> <p>Unacceptable: more than 5 % dewetting on the toe; the bend is well coated</p>
 <p style="text-align: right;"><i>IEC</i></p> <p>Acceptable: some spots of non-ideal coating on the surface are visible.</p>	 <p style="text-align: right;"><i>IEC</i></p> <p>Unacceptable: more than 5 % dewetting of the foot.</p>
 <p style="text-align: right;"><i>IEC</i></p> <p>Acceptable: a few very small irregularities are visible.</p>	 <p style="text-align: right;"><i>IEC</i></p> <p>Unacceptable: more than 5 % of the area not wetted.</p>
<p>The arrows indicate imperfections (acceptable or unacceptable).</p>	

Figure A.1 – Evaluation of wetting

A.1.3 Additional criteria for wetting, method 2

For method 2 (reflow), in addition to A.1.2, the following criteria shall be applied:

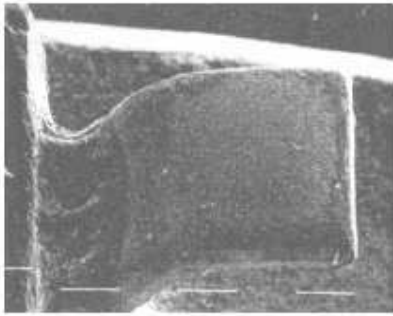
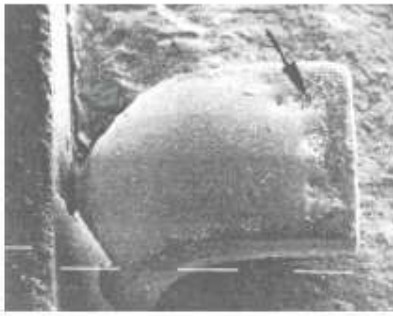
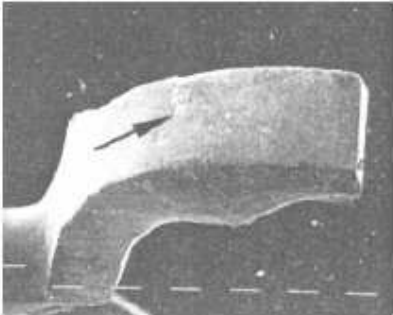
- solder balls at the pins or irregular solder accumulations are not allowed;
- the surface shall be homogenous without irregularities or damages.

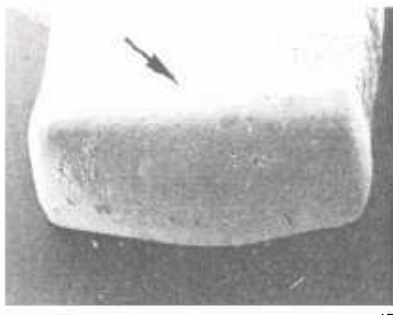
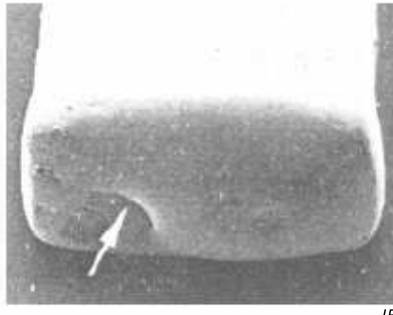
A.2 Evaluation of dewetting, method 2

Figure A.2 comprises four examples illustrating the criteria for visual examination.

Good example (dewetting not present)	Negative example (dewetting > 5 %)
 <p>IEC</p>	 <p>IEC</p> <p>Bad edge covering</p>
 <p>IEC</p>	 <p>IEC</p> <p>“Voids” dewetting</p>

Figure A.2 – Evaluation of dewetting

Annex B (informative)

Guidance

B.1 General

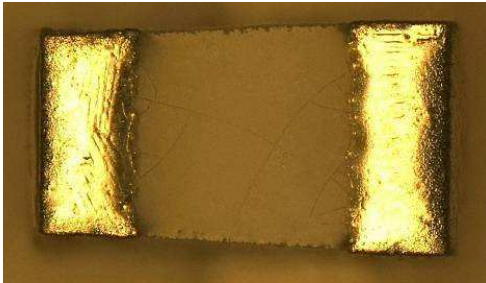
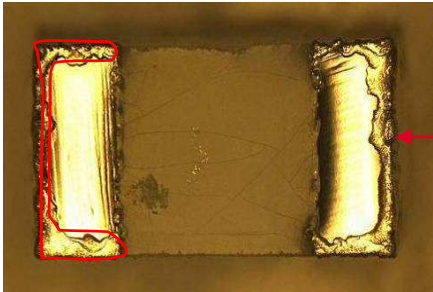
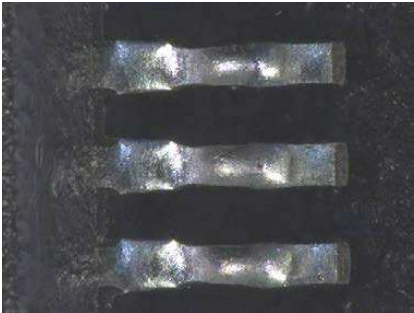
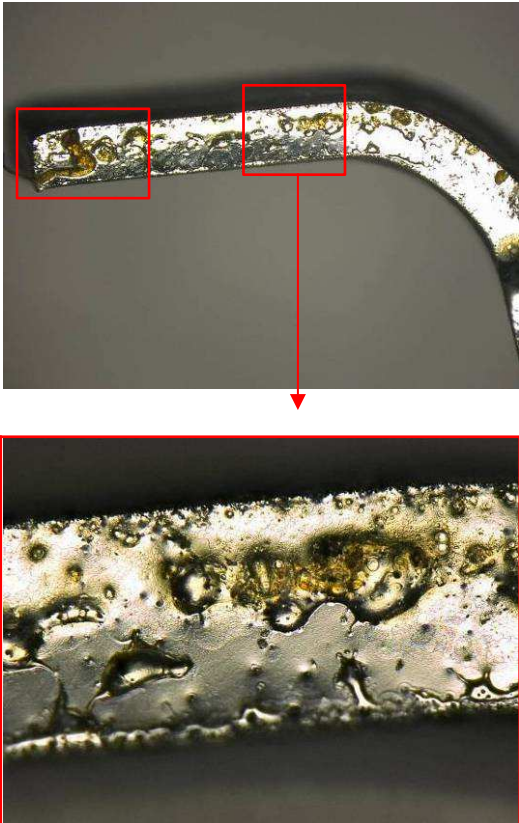
In principle, solderability testing should be quantitative and objective. During the preparation of this standard, consideration has been given to procedures which meet these requirements and these methods may be found in IEC 60068-2-69.

In choosing these conditions, consideration has been given to established procedures¹, as well as the solder bath dip or reflow test conditions already specified in IEC 60068-2-20 and IEC 60749-20.

For components intended for PCB bottom-side mounting and full body immersion during wave soldering, the solder bath method (attitude A) is the preferred condition. In such cases (e.g. for test Td_3), the correlation between the static solder dip conditions and the dynamic wave soldering conditions needs to be considered (i.e., wave soldering imposes more severe conditions on the component compared to dipping into a static solder bath), see B.3.5.

The reflow method has been included for SMDs that are intended for the reflow process only, or to determine the suitability of an SMD for reflow.

Some parts get damaged with reflow temperature profile. Therefore caution should be exercised when choosing reflow profiles and peak reflow temperatures. For example, a semiconductor device to ensure that the moisture sensitivity level (MSL) ratings of these parts are not exceeded (see IEC 60749-20 and IEC 61760-4²).

B.2 Limitations

B.2.1 In the case of specimens having terminations plated with pure tin, or another lead-free plating, there might be a mismatch between the results of the dip test in lead-tin solder bath, and the performance in practice using methods operating below the melting point of tin (for example vapour phase). The solution to this problem is not yet known. In such cases normal production methods or the reflow method may be used as a test procedure.

B.2.2 Excessive peak reflow temperatures initiate failures, which cause equipment failures under normal use conditions.

Solder dipping should only be used if data exists showing that correlation between the part junction temperature under wave solder and dipping is equivalent. In addition, data should exist showing the proper preheating for the correlation.

Preheating is extremely important to prevent damage to parts, especially to large volume packages. Preheating is part of a good process set-up.

B.3 Choice of severity

B.3.1 Test Td_1 : Solderability by solder bath method

The selection of time and temperature values from Table 3 depends on the thermal capacity of the components.

- a) Low thermal capacity and/or high heat resistance component

¹ These procedures have been established by TC 40 and TC 47, by IECQ: IEC Quality Assessment System for Electronic Components <http://www.iecq.org/index.htm> and by the AIE: International Association Of Electrical Contractors.

² To be published.

In Group 2, test condition 235 °C, 2 s is preferred for general components of low thermal capacity.

b) For high thermal capacity component

For components having a high thermal capacity the relevant specification may prescribe an extension of the immersion time up to (10 ± 1) s.

In case of high thermal capacity components with lead, attitude B (floating attitude) or using separated lead should be chosen to avoid drop in solder bath temperature.

B.3.2 Test Td₂: Resistance to soldering heat – Solder bath method

The selection of time and temperature values from Table 6 depends on the thermal capacity and thermal sensitivity of the components.

a) Low thermal capacity and/or high heat resistance component

In group 2 and 3, test condition 260 °C, 10 s is preferred for general components of low thermal capacity and high heat resistance.

b) For high thermal capacity component

Certain soldering methods may require higher severity of (270 ± 3) °C for $(5 \pm 0,5)$ s or the more severe condition of (10 ± 1) s. Such conditions should be provided by the detail specification or as agreed between the trading partners.

The solder bath method cannot be applied to certain large semiconductor packages designed for reflow soldering because the solder bath temperature is higher than the reflow soldering.

c) For low heat resistance component

In case of aluminium electrolytic capacitors with non-solid electrolyte, film dielectric capacitors and connectors, the solder bath method cannot be applied.

B.3.3 Test Td₂: Resistance to soldering heat –Reflow method

The selection of time and temperature values from Table 7 depends on the thermal capacity and thermal sensitivity of the components.

a) Low thermal capacity and/or high heat resistance component

The test conditions in Table B.1 are preferred for general components of low thermal capacity and high heat resistance.

Table B.1 – Test conditions

Group	Alloy name	T ₁ °C	T ₂ °C	t ₁ s	T ₃ °C	t ₂ s	T ₄ °C	t ₃ s	t ₄ s
1	Sn42Bi58				138				
2	Sn63Pb37A Sn60Pb40A	100	150	60 to 120	183	60 to 150	235	20 ± 1	360 max.
3	Sn96,5Ag3Cu,5	150	200		217		260	30 ± 1	480 max.

b) High thermal capacity component

In case of components with high thermal capacity, the temperatures and times given in Table 7 may not always be appropriate, e.g. T₄ cannot be achieved. In such a case t₁, t₂ and t₄ need to be determined such, that t₃ is achieved.

For plastic molded semiconductors, refer to IEC 60749-20.

c) For a low heat resistance component

Temperature and time need to be selected from Table 7 depending on the heat resistance of a component as given by the relevant specification.

For example, in case of aluminium electrolytic capacitors with non-solid electrolyte, the inner electrolyte temperature needs to be kept under the boiling point (e.g. 210 °C).

For information, see J-STD-075.

B.3.4 Immersion attitude

The selection of the immersion attitude in Figure 1 and Figure 3 depends on the thermal capacity of the components.

a) For solderability of the termination

When testing solderability of terminations, certain large flat specimens (for example ceramic chip carriers), if immersed in the solder bath, will absorb heat. In such cases, attitude B (the floating attitude) should be chosen by the detail specification. Discrimination between different sizes of specimens by varying the immersion time is not considered desirable.

b) For resistance to soldering heat

When testing resistance to soldering heat, certain large flat specimens (for example ceramic chip carriers), if immersed with the seating plane vertical, will not experience the thermal gradient across their thickness that they would in practical soldering. In such cases, attitude B (the floating attitude) should be chosen by the detail specification. Discrimination between different sizes of specimens by varying the immersion time is not considered desirable.

B.3.5 Test Td₃: Dewetting and resistance to dissolution of metallization for 30 s at 260 °C

See Table 8.

In wave soldering, the speed of dissolution of metallization is much greater than in a static dip. With wave, reflow or vapour-phase soldering, the specimen may be subjected to subsequent iron soldering for touch-up or repair. A rather long immersion at high temperature can therefore be specified for testing the resistance of the metallization to dissolution in molten solder.

The severities of dewetting and resistance to dissolution of metallization shall depend on the components electrode structure.

Annex C (normative)

Application of the test methods to through hole reflow soldering components (THR)

C.1 Solderability

The solderability of components intended for THR should be tested according IEC 60068-2-20, Test Ta, method 1, but according to the conditions given in Table C.1, which are different from those in IEC 60068-2-20 in order to reflect the conditions of reflow soldering. The relevant specification shall prescribe the preheating before immersion into the solder bath. A typical condition is keeping the test specimen in a distance of 10 mm above the solder bath surface for 30 s.

Table C.1 – Test conditions for solderability test

Solder	Test condition	Preheating
Sn60Pb40A	215 °C, (3 ± 0,3) s	optional
Sn96,5Ag3Cu,5	235 °C, (5 ± 0,5) s	recommended

C.2 Resistance to soldering heat

Test Td₂, method 2, reflow simulation without solder shall be used. The test conditions related to the respective soldering process group apply.

C.3 Dewetting

Test Td₃, method 2, reflow simulation without solder shall be used. The test conditions related to the respective soldering process group apply.

C.4 Criteria for evaluation

The criteria for evaluation shall be provided by the component specification.

Annex X (informative)

Cross reference for references to the prior revision of this specification

The revision of this sectional specification has resulted in a new structure. The following table provides a cross reference for all references to specific elements of the prior revision of this Sectional Specification.

IEC 60068-2-58:2004 3 rd edition Clause/Subclause	IEC 60068-2-58:201X 4 th edition Clause/Subclause	Notes
1	1	—
2	2	—
3	3	—
4	4	—
5	—	The prescriptions on preconditioning are allocated with the separate tests Td ₁ , Td ₂ , or Td ₃ , see below.
5.1	6.2 7.2 8.2	If applied to test Td ₁ If applied to test Td ₂ If applied to test Td ₃
5.2	6.3	—
5.3	7.3	—
6	—	The prescriptions on the solder bath method are allocated with the separate tests Td ₁ , Td ₂ , or Td ₃ , see below.
6.1	—	—
6.1.1	5.1	—
6.1.2	6.5.2 7.5.2 8.4.2	If applied to test Td ₁ If applied to test Td ₂ If applied to test Td ₃
6.1.3	6.5.2 7.5.2 8.4.2	If applied to test Td ₁ If applied to test Td ₂ If applied to test Td ₃
6.2	6.5.3 7.5.3 8.4.3	If applied to test Td ₁ If applied to test Td ₂ If applied to test Td ₃
7	—	The prescriptions on the solder reflow method are allocated with the separate tests Td ₁ , Td ₂ , or Td ₃ , see below.
7.1	—	—
7.1.1	5.2	—
7.1.2	6.6.2 7.6.2 8.5.3	If applied to test Td ₁ If applied to test Td ₂ If applied to test Td ₃
7.1.3	6.6.3 7.6.3	If applied to test Td ₁ If applied to test Td ₂
7.2	6.6.4 7.6.4	If applied to test Td ₁ If applied to test Td ₂

IEC 60068-2-58:2004 3 rd edition Clause/Subclause	IEC 60068-2-58:201X 4 th edition Clause/Subclause	Notes
8	—	—
8.1	—	The prescriptions concerning lead-free solder alloys are allocated with the separate tests Td ₁ , Td ₂ , or Td ₃ , see below.
8.1.1	6.5.3.5 7.5.3.5	If applied to test Td ₁ If applied to test Td ₂
8.1.2	—	—
8.1.2.1	6.6.6	—
8.1.2.2	7.6.4.4	—
8.2	—	The prescriptions concerning lead containing solder alloys are allocated with the separate tests Td ₁ , Td ₂ , or Td ₃ , see below.
8.2.1	6.5.3.5 7.5.3.5 8.4.3	If applied to test Td ₁ If applied to test Td ₂ If applied to test Td ₃
8.2.2	6.6.6 7.6.4.4	If applied to test Td ₁ If applied to test Td ₂
8.2.3	6.6.6	—
8.2.4	7.6.4.4	—
9	9	—
10	10	—
Annex A	Annex A	—
Annex B	Annex B	—
Annex C	—	Information relevant to components for through-hole reflow soldering is available in IEC 61760-3.
Bibliography	Bibliography	—

Bibliography

IEC 60068-2-54, *Environmental testing – Part 2-54: Tests – Test Ta: Solderability testing of electronic components by the wetting balance method*

IEC 60068-2-69, *Environmental testing – Part 2-69: Tests – Test Te: Solderability testing of electronic components for surface mounting devices (SMD) by the wetting balance method*

IEC TR 60068-3-12, *Environmental testing – Part 3-12: Supporting documentation and guidance – Method to evaluate a possible lead-free solder reflow temperature profile*

IEC 60068-3-13, *Environmental testing – Part 3-13: Guidance on Test T: Soldering*³

IEC 60749-20, *Semiconductor devices – Mechanical and climatic test methods – Part 20: Resistance of plastic-encapsulated SMDs to the combined effect of moisture and soldering heat*

IEC 61760-3, *Surface mounting technology – Part 3: Standard method for the specification of components for through hole reflow (THR) soldering*

IEC 61760-4, *Surface mounting technology – Part 4: Standard method for classification, packaging, labelling and handling of moisture sensitive devices*⁴

J-STD 020D, *Moisture/Reflow Sensitivity Classification for Nonhermetic Solid State Surface Mount Devices*

<http://www.jedec.org/sites/default/files/docs/jstd020d-01.pdf>

J-STD 075, *Classification of Non-IC Electronic Components for Assembly Processes*

³ Under consideration.

⁴ To be published.

INTERNATIONAL
ELECTROTECHNICAL
COMMISSION

3, rue de Varembé
PO Box 131
CH-1211 Geneva 20
Switzerland

Tel: + 41 22 919 02 11
Fax: + 41 22 919 03 00
info@iec.ch
www.iec.ch